

Accessory Design Guidelines for Apple Devices

Release R5

Contents

Introduction 11

- 1. Introduction 12**
 - 1.1 Purpose of This Specification 12
 - 1.2 Requirements, Recommendations, and Permissions 12
 - 1.3 Terminology 13
 - 1.3.1 Accessory, Device, and Product 13

Accessories 14

- 2. All Accessories 15**
 - 2.1 Attachments 15
 - 2.2 Magnetic Interference 15
 - 2.3 Radio Frequency (RF) Performance 15
 - 2.3.1 Materials and Coatings 15
 - 2.3.2 Antenna Keep-Out 16
 - 2.3.3 Over The Air (OTA) 16
 - 2.3.4 Near Field Communication (NFC) 17
 - 2.4 Qi Wireless Power 17
- 3. Cases 18**
 - 3.1 Product Design 18
 - 3.1.1 Device Protection 18
 - 3.1.2 Access to Inputs and Interconnects 19
 - 3.1.3 Dock Compatibility 21
 - 3.2 Acoustics 21
 - 3.2.1 Call Quality 21
 - 3.2.2 Speaker to Microphone Coupling 21
 - 3.2.3 Speaker/Microphone Openings 22
 - 3.3 Ambient Light Sensor and Proximity Sensor Interference 24
 - 3.4 Taptic Engine 24
 - 3.5 Magnetic Interference 25
 - 3.6 Home Button / Touch ID Sensor 25

- 3.7 Camera 25
 - 3.7.1 Geometry 25
 - 3.7.2 Color 26
 - 3.7.3 Surface Finish 26
 - 3.7.4 Image Degradation Examples 26
- 3.8 Reliability 27
 - 3.8.1 Device Insertion and Removal 27
 - 3.8.2 Colorfastness 27
- 3.9 Environmental 28
- 3.10 Test Procedures 28
 - 3.10.1 Required Apple Device Models 28
 - 3.10.2 Product Design 32
 - 3.10.3 Taptic Engine 34
 - 3.10.4 Home Button / Touch ID Sensor Overlays 35
 - 3.10.5 Acoustics 36

- 4. Covers 38**
 - 4.1 Magnetic Interference 38
 - 4.2 Smart Covers 38

- 5. Screen Overlays 39**
 - 5.1 Product Design 39
 - 5.2 Edge Swipe Gestures 39
 - 5.3 Edge Press Gestures 40

- 6. Camera Attachments 41**
 - 6.1 Magnetic Interference 41

- 7. Apple AirPods Attachments 42**
 - 7.1 Interference 42

Bluetooth 44

- 8. Bluetooth Introduction 45**
 - 8.1 Apple Bluetooth Development Mailing List 45

- 9. Bluetooth 46**
 - 9.1 Enhanced Data Rate 46
 - 9.2 Adaptive Frequency Hopping 46

- 9.3 Sniff Mode for Low Power Consumption 46
- 9.4 Role and Topology Management 47
- 9.5 Extended Inquiry Response 48
- 9.6 Secure Simple Pairing 48
- 9.7 Pairing Button 48
- 9.8 Class of Device (CoD) 49
- 9.9 Link Supervision Timeout 49
- 9.10 Delay Reporting 49
- 9.11 Profiles 49
 - 9.11.1 Device ID Profile (DID) 49
 - 9.11.2 Service Discovery Protocol (SDP) 50
 - 9.11.3 Hands-Free Profile (HFP) 50
 - 9.11.4 Message Access Profile (MAP) 53
 - 9.11.5 Audio/Video Remote Control Profile (AVRCP) 53
 - 9.11.6 Advanced Audio Distribution Profile (A2DP) 55
- 9.12 Audio Routing 55
 - 9.12.1 Audio Data Received via HFP Profile 56
 - 9.12.2 Audio Data Received via A2DP Profile 56
- 9.13 HID 58
- 10. Bluetooth Low Energy 59**
 - 10.1 Role 59
 - 10.2 Advertising Channels 59
 - 10.3 Advertising PDU 59
 - 10.4 Advertising Data 59
 - 10.5 Advertising Interval 60
 - 10.6 Connection Parameters 61
 - 10.7 Data Packet Length Extension 61
 - 10.8 Privacy 62
 - 10.9 Permissions 62
 - 10.10 Pairing 62
 - 10.11 MTU Size 63
 - 10.12 Services 63
 - 10.12.1 Generic Access Profile Service 63
 - 10.12.2 Generic Attribute Profile Service 63
 - 10.12.3 Device Information Service 64
 - 10.12.4 Available Services 64
 - 10.13 GATT Server 64
- 11. Advanced Audio Distribution Profile (A2DP) 66**

- 11.1 Bluetooth A2DP Specification 66
 - 11.1.1 AVDTP Transactions 66
- 11.2 SubBand Codec (SBC) 66
- 11.3 MPEG 2/4 AAC Codecs 67
- 11.4 Test Procedures 68
 - 11.4.1 Audio Quality 68
 - 11.4.2 Audio Switching 68
 - 11.4.3 HFP Interaction 68
 - 11.4.4 Siri 68
 - 11.4.5 Video Playback 68

- 12. Bluetooth Accessory Identification 69**
 - 12.1 HFP Command AT+XAPL 69

- 13. Bluetooth Headset Battery Level Indication 71**
 - 13.1 HFP Command AT+IPHONEACCEV 71

- 14. Siri 72**
 - 14.1 Enabling Custom Siri Commands 72
 - 14.2 Obtaining Siri Availability Information 72
 - 14.2.1 Obtaining Status Information at Connection 72
 - 14.2.2 Receiving Siri Availability Updates from the Apple Device 73
 - 14.3 Initiating a Siri Session 74
 - 14.3.1 Initiating a Session from the Accessory 74
 - 14.3.2 Initiating a Session from the Apple Device 75
 - 14.3.3 Ending a Session from the Accessory 75
 - 14.4 Siri Eyes Free Mode 76
 - 14.4.1 HFP Command AT+APLEFM 76
 - 14.5 Improving Voice Recognition 77
 - 14.5.1 Wide Band Speech Support 77
 - 14.6 Optimizing the Siri Experience 78
 - 14.7 Common Siri Applications 78
 - 14.7.1 Initialization Procedure After Connection is Established 78
 - 14.7.2 Phone Dialing Using Siri 79
 - 14.7.3 Audio Routing and Media Playback Using Siri 79
 - 14.7.4 Turn-By-Turn Directions Using Siri 80
 - 14.8 User Interaction with Siri Eyes Free in a Vehicle 80
 - 14.9 Enabling/Disabling Siri from the Apple Device 82
 - 14.10 Test Procedures 83
 - 14.10.1 Siri Eyes Free 83

15. iPod Accessory Protocol 87**References** 88**16. Device Dimensional Drawings** 89

16.1 iPhone X	91
16.2 iPhone 8 Plus	92
16.3 iPhone 8	93
16.4 iPhone 7 Plus	94
16.5 iPhone 7	95
16.6 iPhone 6s Plus	96
16.7 iPhone 6s	97
16.8 iPhone 6 Plus	98
16.9 iPhone 6	99
16.10 iPhone 5s & iPhone SE	100
16.11 iPhone 5c	101
16.12 iPhone 5	102
16.13 iPad Pro (10.5-inch) with Wi-Fi	103
16.14 iPad Pro (10.5-inch) with Wi-Fi + Cellular	104
16.15 iPad Pro (10.5-inch) Magnet/Hall Effect Sensors	105
16.16 iPad Pro (12.9-inch) 2nd Generation with Wi-Fi	107
16.17 iPad Pro (12.9-inch) 2nd Generation with Wi-Fi + Cellular	108
16.18 iPad Pro (12.9-inch) 2nd Generation Magnet/Hall Effect Sensors	109
16.19 iPad (5th and 6th generation) with Wi-Fi + Cellular	111
16.20 iPad (5th and 6th generation) Magnet/Hall Effect Sensors	112
16.21 iPad Pro (9.7-inch) with Wi-Fi	114
16.22 iPad Pro (9.7-inch) with Wi-Fi + Cellular	115
16.23 iPad Pro (9.7-inch) Magnet/Hall Effect Sensors	116
16.24 iPad Pro (12.9-inch) 1st Generation with Wi-Fi	118
16.25 iPad Pro (12.9-inch) 1st Generation with Wi-Fi + Cellular	119
16.26 iPad Pro (12.9-inch) 1st Generation Magnet/Hall Effect Sensors	120
16.27 iPad mini 4 with Wi-Fi	122
16.28 iPad mini 4 with Wi-Fi + Cellular	123
16.29 iPad mini 4 Magnet/Hall Effect Sensors	124
16.30 iPad Air 2 with Wi-Fi	125
16.31 iPad Air 2 with Wi-Fi + Cellular	126
16.32 iPad mini 2 & iPad mini 3 with Wi-Fi	127
16.33 iPad mini 2 & iPad mini 3 with Wi-Fi + Cellular	128

16.34 iPad Air with Wi-Fi	129
16.35 iPad Air with Wi-Fi + Cellular	130
16.36 iPad mini with Wi-Fi	131
16.37 iPad mini with Wi-Fi + Cellular	132
16.38 iPad (4th generation) with Wi-Fi	133
16.39 iPad (4th generation) with Wi-Fi + Cellular	134
16.40 iPod touch (6th generation)	135
16.41 iPod touch (5th generation)	136
Revision History	137
Added Content	137
Updated Content	137

Figures and Tables

3. Cases	18	
Figure 3-1	Device Protection	19
Figure 3-2	Touchscreen keep-out area	20
Figure 3-3	Microphone/speaker opening recommendations for thin cases	22
Figure 3-4	Thick case acoustic channels	23
Figure 3-5	Thick case microphone and speaker exit separation	23
Figure 3-6	Improper thick case seal	24
Figure 3-7	Sample image degradation by image blocking in ambient condition	26
Figure 3-8	Sample image degradation by color shift through accessory with strong color	27
Figure 3-9	Sample image degradation by flash interference	27
Figure 3-10	Apple device proudness test	33
Figure 3-11	Apple device gap test	33
Figure 3-12	Apple device touchscreen keep-out test	34
Table 3-1	iPhone X Case Testing Matrix	28
Table 3-2	iPhone 8 Plus/iPhone 7 Plus Case Testing Matrix	28
Table 3-3	iPhone 8/iPhone 7 Case Testing Matrix	29
Table 3-4	iPhone 6s Plus/iPhone 6 Plus Case Testing Matrix	29
Table 3-5	iPhone 6s/iPhone 6 Case Testing Matrix	29
Table 3-6	iPhone 5/iPhone 5s/iPhone SE Case Testing Matrix	29
Table 3-7	iPhone 5c Case Testing Matrix	30
Table 3-8	iPad Pro (10.5-inch) Case Testing Matrix	30
Table 3-9	iPad Pro (12.9-inch) 2nd Generation Case Testing Matrix	30
Table 3-10	iPad (5th and 6th generation) Case Testing Matrix	30
Table 3-11	iPad Pro (9.7-inch) Case Testing Matrix	30
Table 3-12	iPad Pro (12.9-inch) 1st Generation Case Testing Matrix	30
Table 3-13	iPad mini 4 Case Testing Matrix	31
Table 3-14	iPad mini/iPad mini 2/iPad mini 3 Case Testing Matrix	31
Table 3-15	iPad Air 2 Case Testing Matrix	31
Table 3-16	iPad Air Case Testing Matrix	31
Table 3-17	iPad (4th generation) Case Testing Matrix	31
Table 3-18	iPod touch (5th generation)/iPod touch (6th generation) Case Testing Matrix	31
7. Apple AirPods Attachments	42	
Figure 7-1	AirPods Keep-Out Drawing	43

9. Bluetooth 46

- Figure 9-1 Initiate Audio Playback (e.g. music) 57
- Figure 9-2 Initiate System Sound (e.g. turn-by-turn directions) 57

10. Bluetooth Low Energy 59

- Figure 10-1 Data Packet Length Extension 62

11. Advanced Audio Distribution Profile (A2DP) 66

- Table 11-1 SubBand Codec Information Elements for Apple products 66
- Table 11-2 MPEG-2/4 AAC Codec Information Elements for Apple devices 67
- Table 11-3 AAC audio packet for Apple devices 67

14. Siri 72

- Figure 14-1 Siri is Disabled/Enabled from the Apple Device's Settings 73
- Figure 14-2 Initiating a Siri Session from the Accessory 74
- Figure 14-3 Initiating a Siri Session from the Apple Device 75
- Figure 14-4 Ending a Siri Session from the Accessory 76
- Figure 14-5 Siri Initialization Procedure 79
- Figure 14-6 Siri Initialization Procedure with Siri Eyes Free 79
- Figure 14-7 Siri Eyes Free User Interaction 81
- Figure 14-8 Siri is Deactivated - Launching Voice Control 82
- Figure 14-9 Siri is Deactivated - Displaying a Warning Message 82

16. Device Dimensional Drawings 89

- Figure 16-1 iPhone X Dimensional Drawing 91
- Figure 16-2 iPhone 8 Plus Dimensional Drawing 92
- Figure 16-3 iPhone 8 Dimensional Drawing 93
- Figure 16-4 iPhone 7 Plus Dimensional Drawing 94
- Figure 16-5 iPhone 7 Dimensional Drawing 95
- Figure 16-6 iPhone 6s Plus Dimensional Drawing 96
- Figure 16-7 iPhone 6s Dimensional Drawing 97
- Figure 16-8 iPhone 6 Plus Dimensional Drawing 98
- Figure 16-9 iPhone 6 Dimensional Drawing 99
- Figure 16-10 iPhone 5s & iPhone SE Dimensional Drawing 100
- Figure 16-11 iPhone 5c Dimensional Drawing 101
- Figure 16-12 iPhone 5 Dimensional Drawing 102
- Figure 16-13 iPad Pro (10.5-inch) with Wi-Fi Dimensional Drawing 103
- Figure 16-14 iPad Pro (10.5-inch) with Wi-Fi + Cellular Dimensional Drawing 104
- Figure 16-15 iPad Pro (10.5-inch) Magnet/Hall Effect Sensors 1 of 2 Dimensional Drawing 105
- Figure 16-16 iPad Pro (10.5-inch) Magnet/Hall Effect Sensors 2 of 2 Dimensional Drawing 106

Figure 16-17	iPad Pro (12.9-inch) 2nd Generation with Wi-Fi Dimensional Drawing	107
Figure 16-18	iPad Pro (12.9-inch) 2nd Generation with Wi-Fi + Cellular Dimensional Drawing	108
Figure 16-19	iPad Pro (12.9-inch) 2nd Generation Magnet/Hall Effect Sensors 1 of 2 Dimensional Drawing	109
Figure 16-20	iPad Pro (12.9-inch) 2nd Generation Magnet/Hall Effect Sensors 2 of 2 Dimensional Drawing	110
Figure 16-21	iPad (5th and 6th generation) with Wi-Fi + Cellular Dimensional Drawing	111
Figure 16-22	iPad (5th and 6th generation) Magnet/Hall Effect Sensors 1 of 2 Dimensional Drawing	112
Figure 16-23	iPad (5th and 6th generation) Magnet/Hall Effect Sensors 2 of 2 Dimensional Drawing	113
Figure 16-24	iPad Pro (9.7-inch) with Wi-Fi Dimensional Drawing	114
Figure 16-25	iPad Pro (9.7-inch) with Wi-Fi + Cellular Dimensional Drawing	115
Figure 16-26	iPad Pro (9.7-inch) Magnet/Hall Effect Sensors 1 of 2 Dimensional Drawing	116
Figure 16-27	iPad Pro (9.7-inch) Magnet/Hall Effect Sensors 2 of 2 Dimensional Drawing	117
Figure 16-28	iPad Pro (12.9-inch) 1st Generation with Wi-Fi Dimensional Drawing	118
Figure 16-29	iPad Pro (12.9-inch) 1st Generation with Wi-Fi + Cellular Dimensional Drawing	119
Figure 16-30	iPad Pro (12.9-inch) 1st Generation Magnet/Hall Effect Sensors 1 of 2 Dimensional Drawing	120
Figure 16-31	iPad Pro (12.9-inch) 1st Generation Magnet/Hall Effect Sensors 2 of 2 Dimensional Drawing	121
Figure 16-32	iPad mini 4 with Wi-Fi Dimensional Drawing	122
Figure 16-33	iPad mini 4 with Wi-Fi + Cellular Dimensional Drawing	123
Figure 16-34	iPad mini 4 Magnet/Hall Effect Sensors Dimensional Drawing	124
Figure 16-35	iPad Air 2 with Wi-Fi Dimensional Drawing	125
Figure 16-36	iPad Air 2 with Wi-Fi + Cellular Dimensional Drawing	126
Figure 16-37	iPad mini 2 & iPad mini 3 with Wi-Fi Dimensional Drawing	127
Figure 16-38	iPad mini 2 & iPad mini 3 with Wi-Fi + Cellular Dimensional Drawing	128
Figure 16-39	iPad Air with Wi-Fi Dimensional Drawing	129
Figure 16-40	iPad Air with Wi-Fi + Cellular Dimensional Drawing	130
Figure 16-41	iPad mini with Wi-Fi Dimensional Drawing	131
Figure 16-42	iPad mini with Wi-Fi + Cellular Dimensional Drawing	132
Figure 16-43	iPad (4th generation) with Wi-Fi Dimensional Drawing	133
Figure 16-44	iPad (4th generation) with Wi-Fi + Cellular Dimensional Drawing	134
Figure 16-45	iPod touch (6th generation) Dimensional Drawing	135
Figure 16-46	iPod touch (5th generation) Dimensional Drawing	136

Introduction

1. Introduction

Note: These Accessory Design Guidelines for Apple Devices ('Guidelines') are subject to the terms and conditions set forth on the final page of this document. By downloading, accessing, or otherwise utilizing these Guidelines, you agree to be bound by, and only utilize the Guidelines in accordance with, such terms and conditions.

1.1 Purpose of This Specification

These guidelines address:

- The physical design of cases, covers, screen overlays, and camera attachments for Apple devices.
- The specifications for hardware accessories that use the Bluetooth transport to communicate with Apple products including Mac, iPhone, iPad, and iPod touch models.
- The design of wireless power transmitters for Apple devices.

These guidelines do not address other aspects of accessory communication with Apple devices. Instead, see the MFi Program (<https://developer.apple.com/programs/mfi/>).

1.2 Requirements, Recommendations, and Permissions

This specification contains statements that are incorporated by reference into legal agreements between Apple and its licensees. The use of the words *must*, *must not*, *required*, *shall*, *shall not*, *should*, *should not*, *recommended*, *not recommended*, *may*, *optional*, and *deprecated* in a statement have the following meanings:

- *must*, *shall*, or *required* means the statement is an absolute requirement.
- *must not*, *shall not* or *prohibited* means the statement is an absolute prohibition.
- *should* or *recommended* means the full implications must be understood before choosing a different course.
- *should not* or *not recommended* means the full implications must be understood before choosing this course.
- *may* or *optional* means the statement is truly optional, and its presence or absence cannot be assumed.
- *deprecated* means the statement is provided for historical purposes only and is equivalent to 'must not'.

The absence of requirements, recommendations, or permissions for a specific accessory design in this specification must not be interpreted as implied approval of that design. Developers are strongly encouraged to ask Apple for feedback on accessory designs that are not explicitly mentioned in this specification.

1.3 Terminology

1.3.1 Accessory, Device, and Product

Throughout this specification:

- The term *device* is used to refer to:
 - An Apple iPhone, iPad, or iPod (typically running iOS, Apple's mobile operating system).
 - An Apple Watch (typically running watchOS, Apple's watch operating system).
 - An Apple TV (typically running tvOS, Apple's television operating system).
- The term *accessory* is used to refer to any product intended to interface with a *device* via the means described in this specification.
- The term Apple *product* is used to refer generically to either a Mac (Apple computers that run macOS or OS X) or to an aforementioned *device*.

Statements that explicitly mention iOS, watchOS, tvOS, or macOS / OS X apply only to products running those operating systems.

Accessories

2. All Accessories

The requirements in this section apply to all accessories regardless of their feature sets.

2.1 Attachments

Accessories must remain compliant with the specification when connected to any attachments designed for that accessory.

Examples of accessory attachments include, but are not limited to:

- Car or desk mounts for a case accessory.
- Wireless charging mats for a dongle or case accessory.
- Detachable barcode scanners/credit card readers for a dock accessory.

2.2 Magnetic Interference

Apple recommends avoiding the use of magnets and metal components in accessories.

All accessories claiming compatibility with Apple devices that contain a digital compass (magnetometer) must minimize interference with the digital compass and must not repeatedly trigger compass recalibration.

All accessories claiming compatibility with Apple devices that contain rear camera autofocus (AF) and/or optical image stabilization (OIS) features must not affect the operation of these features.

2.3 Radio Frequency (RF) Performance

This section contains RF performance requirements and recommendations for all accessories.

2.3.1 Materials and Coatings

Accessories should avoid use of:

- Metals
- Conductive materials or coatings

- Materials with high dielectric (permittivity >5 F/m)

Such materials absorb radio frequency energy and may impair or degrade the performance of antennas for cellular communication, GPS, Wi-Fi, Bluetooth, and NFC.

Examples include (but are not limited to) the following:

- Steel, aluminum, magnesium, titanium, etc.
- Plastics with any carbon content
- Plastics with any glass content
- Plastics with metallic plating
- Metallic paints
- Black paints with high carbon loading
- White paints with high titanium dioxide loading
- Metallic Physical Vapor Deposition (PVD) coatings

2.3.2 Antenna Keep-Out

Antenna keep-out regions (also labeled as "No Metal Contact") can be found in the device dimensional drawings, see [Device Dimensional Drawings](#) (page 89).

Accessory materials or coatings that absorb radio frequency energy (see [Materials and Coatings](#) (page 15)) in the antenna keep-out region have a higher risk of degrading Apple device wireless performance.

2.3.3 Over The Air (OTA)

Accessories must not excessively degrade the Apple device's RF transmission efficiency. This can be quantified by measuring Total Radiated Power (TRP) across all of the device's operating bands.

Accessories must not excessively degrade the Apple device's RF reception sensitivity. This can be quantified by measuring Effective Isotropic Sensitivity (EIS) across all of the device's operating bands.

Accessories may have a higher risk of excessively degrading Apple device RF performance if they:

- Contain magnets.
- Intrude on Apple device antenna keep-out zones (see [Antenna Keep-Out](#) (page 16)).

All accessory configurations must be taken into account when designing for maximum RF compatibility.

Examples include, but are not limited to:

- Accessory on/off
- Accessory open/closed
- Attachment present/not present (see [Attachments](#) (page 15))

2.3.4 Near Field Communication (NFC)

Accessories that intrude on Apple device antenna keep-out zones (see [Antenna Keep-Out](#) (page 16)) and claim compatibility with NFC enabled Apple devices must not degrade device NFC transaction performance.

The following Apple devices are NFC enabled:

- iPhone X
- iPhone 8 Plus
- iPhone 8
- iPhone 7 Plus
- iPhone 7
- iPhone SE
- iPhone 6s Plus
- iPhone 6s
- iPhone 6 Plus
- iPhone 6

2.4 Qi Wireless Power

Accessories that incorporate a Qi transmitter or receiver must be certified according to *The Qi Power Transfer System, Power Class 0* standard, version 1.2.4, see <https://www.wirelesspowerconsortium.com>.

3. Cases

Accessories that substantially enclose Apple devices must comply with the requirements stated in this chapter unless the accessory supports other features in this specification whose requirements conflict with the requirements in this chapter.

If the accessory has multiple user-detachable components that substantially enclose the Apple device, the requirements and/or overrides must be applied to each component separately.

3.1 Product Design

A well-designed case will securely house an Apple device while not interfering with the device's operation. Significant factors in mechanical design include access to the device's sensors, controls, and connectors. Dimensional drawings for all Apple devices can be found in [Device Dimensional Drawings](#) (page 89).

3.1.1 Device Protection

Cases must protect the Apple device from a 1 m drop onto a hard paved surface in any device orientation. Specifically, exposed glass on the Apple device must not come within 1 mm of a flat surface, such as a table or floor, in any orientation when the case is attached. This may be achieved by either covering the exposed glass or creating features around it that will space the exposed glass at least 1 mm away from the flat surface.

Care should be given to the design of the bottom of the case to achieve both device protection and access to device speakers, microphones, and connectors. For instance, the bottom of iPhone X cases should:

- Not have an opening wider than 50 mm (see dimension A in [Figure 3-1](#) (page 19)).
- Be made of polycarbonate (PC) at least 1.15 mm thick (see dimension B in [Figure 3-1](#) (page 19)).

Figure 3-1 Device Protection

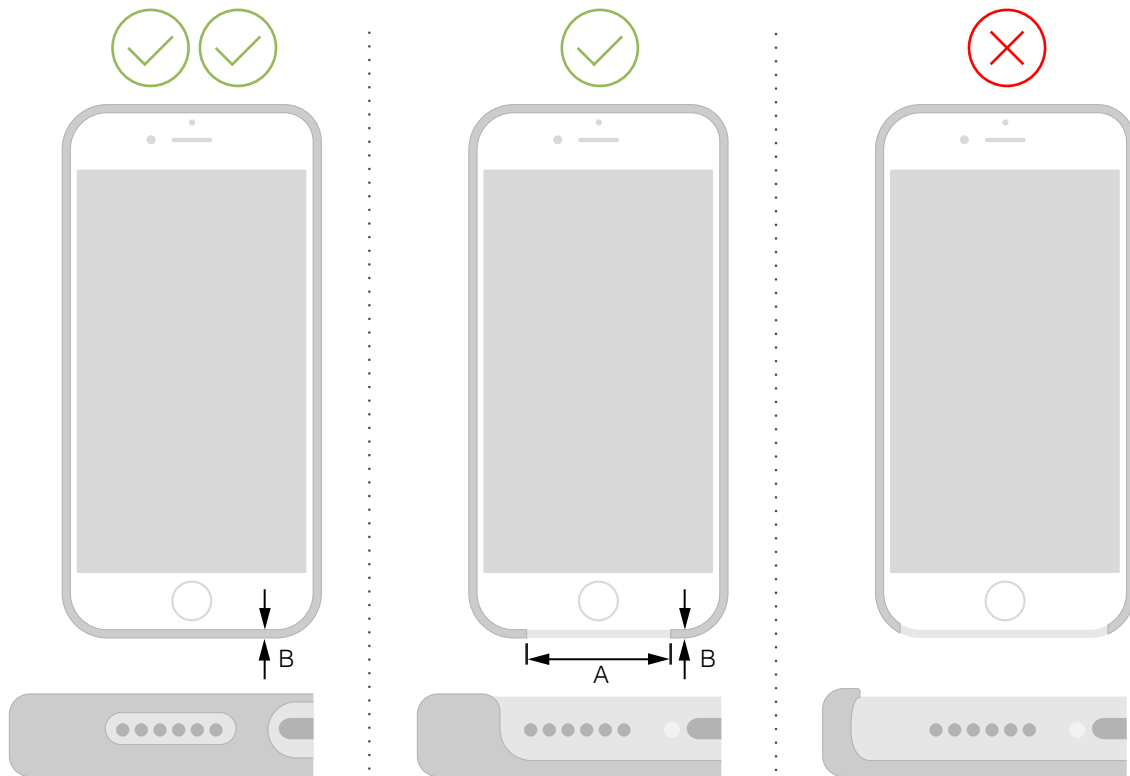

3.1.2 Access to Inputs and Interconnects

The accessory must readily permit the user to access inputs and interconnects.

3.1.2.1 Access to Controls

The accessory must readily permit the user to access and operate the device's mechanical controls, such as:

- Volume buttons
- Ring/Silent switch
- Side button
- Home/Touch ID sensor
- Home button
- Sleep/Wake button

3.1.2.2 Access to the Headset Jack and Lightning Connector

The accessory must provide ready access to an Apple device's headset jack. The headset jack opening (i.e., keep-out area) must be at least 6.0 mm in diameter and at most 14.0 mm deep. At least 6.5 mm in diameter and at most 10.0 mm deep is recommended for best compatibility with a range of headsets.

The accessory must also provide unobstructed access to the Lightning connector.

If the accessory is for an Apple device with the Lightning connector, the opening (i.e., keep-out area) must be at least 12.05 mm by 6.30 mm with full radii rounded edges. 13.65 mm by 6.85 mm is recommended for best compatibility with a range of cables and docks.

In addition, the headset jack and Lightning connector openings must be designed with enough margin to compensate for shifting or dimensional changes of the accessory material.

3.1.2.3 Access to the Smart Connector

Accessories that do not make use of the Smart Connector must not expose it.

3.1.2.4 Touchscreen

The accessory should not have any edges that can collect water on the touchscreen area when the Apple device is held at a 30° angle relative to the horizon.

Accessories must allow a 120° opening along the edges of the active area of the touchscreen to ensure compatibility with the Apple device touchscreen features. See [Figure 3-2](#) (page 20) for more information on the keep-out and [Device Dimensional Drawings](#) (page 89) device specific active display areas.

Figure 3-2 Touchscreen keep-out area

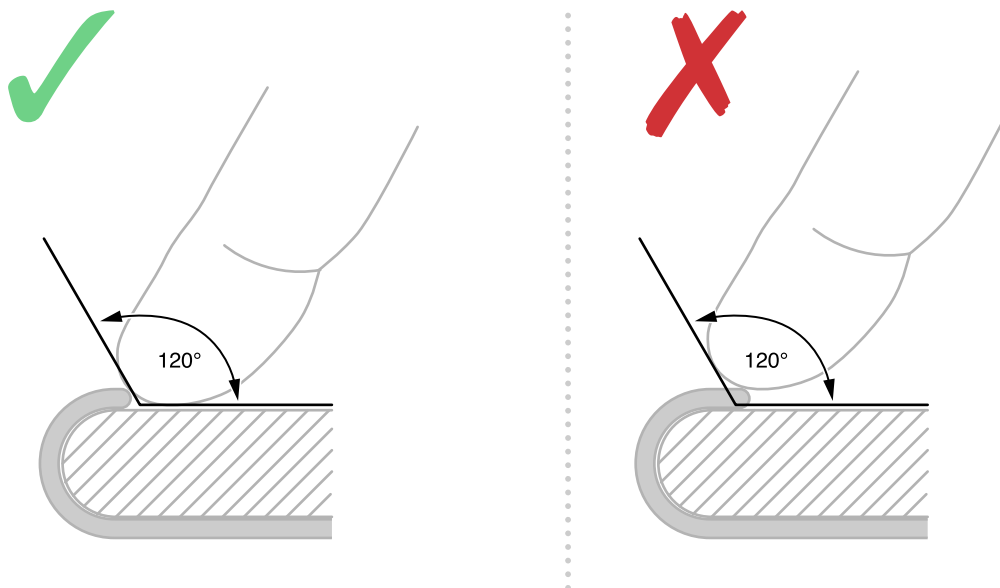

3.1.2.5 Cover Glass Contact

Cases that claim compatibility with the following Apple devices should not contact the cover glass as defined in their dimensional drawings:

- iPhone X
- iPhone 8 Plus
- iPhone 8
- iPhone 7 Plus
- iPhone 7
- iPhone 6s Plus
- iPhone 6s
- iPhone 6 Plus
- iPhone 6

See [Device Dimensional Drawings](#) (page 89).

3.1.3 Dock Compatibility

For compatibility with docks, the distance from bottom of the Apple device to the outside of a case should not exceed 1.8 mm.

3.2 Acoustics

The accessory must not impair or degrade the acoustic performance of an Apple device.

3.2.1 Call Quality

The accessory must not impair or degrade the user's experience making and receiving both audio calls over a cellular network or audio/video calls using FaceTime in both handset and speakerphone modes. The accessory should not change the frequency response of the speakers or microphones. In addition, the user should not hear any distortion or echo resulting from the accessory.

The accessory must not obstruct any microphones during a phone call. Note that occluding any microphones can result in call quality degradation.

3.2.2 Speaker to Microphone Coupling

Cases must not facilitate the conduction of sound from any speaker to any microphone. Such sound conduction may cause echoing in phone calls.

3.2.3 Speaker/Microphone Openings

Apple device speaker/microphone port locations vary from model to model, see [Device Dimensional Drawings](#) (page 89).

3.2.3.1 Thin Cases (≤ 2.25 mm)

Microphone/speaker openings in thin cases should:

- Be offset at least 2.0 mm from the edge of any Apple device speaker/microphone port.
- Be at most 1.5 mm thick along their inner diameter.
- Have a maximum 45° incoming angle to their inner diameter.
- Maintain a proper seal against the Apple device between speaker/microphone ports.

Figure 3-3 Microphone/speaker opening recommendations for thin cases

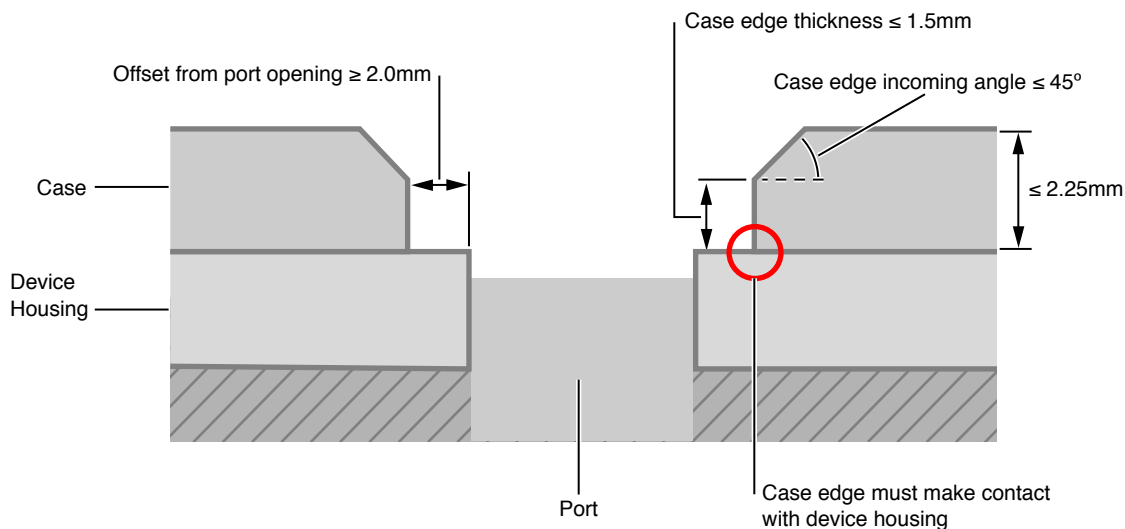

3.2.3.2 Thick Cases (>2.25 mm)

Speaker and microphone openings should be channeled independently and without interruption to/from the outside surface of a thick case.

Figure 3-4 Thick case acoustic channels

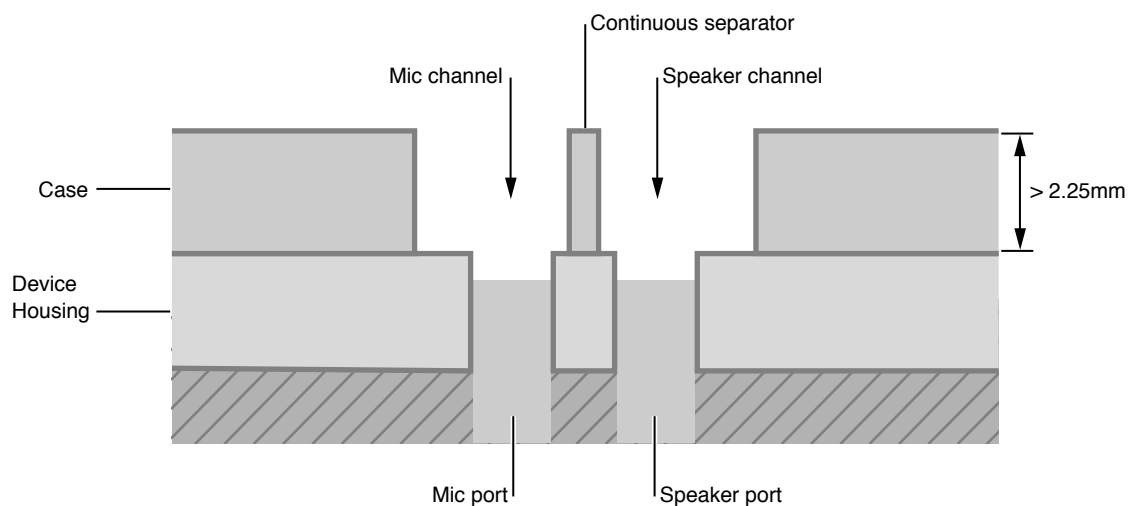

Thick cases should maximize exit separation between speaker and microphone channels.

Figure 3-5 Thick case microphone and speaker exit separation

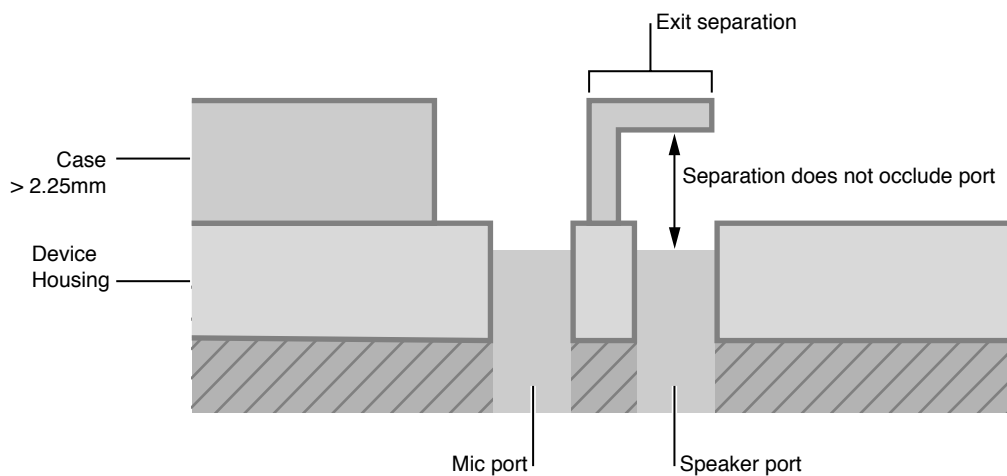

Thick case channels may act as a resonant chamber and detune microphone/speaker frequency response. The resulting frequency response may vary according to channel size/shape.

If a thick case does not maintain a proper seal against the Apple device between microphone/speaker channels, the case itself may become an acoustic chamber.

Figure 3-6 Improper thick case seal

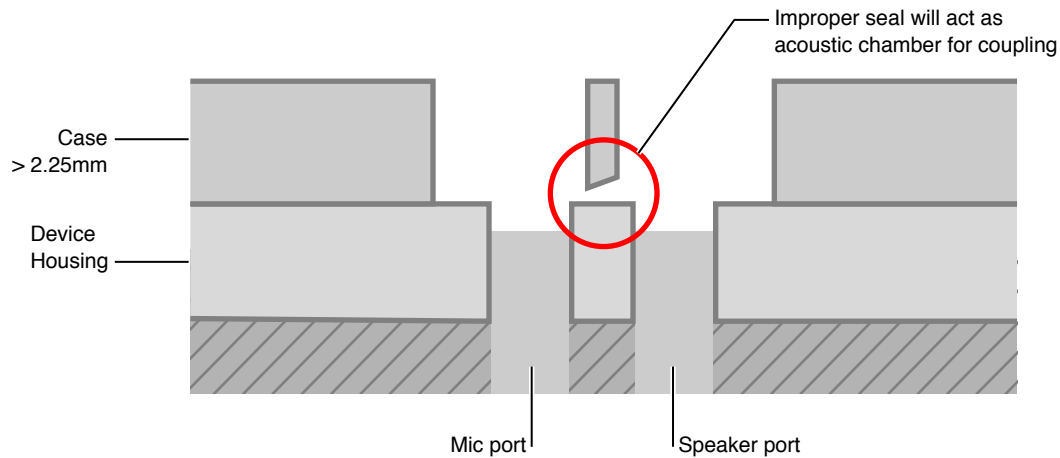

3.3 Ambient Light Sensor and Proximity Sensor Interference

The ambient light sensor and proximity sensor locations for various Apple devices are shown in the dimensional drawings cited in [Device Dimensional Drawings](#) (page 89). Some of the dimensional drawings specify a recommended keep-out area around these sensors. No material must be allowed to cover these sensors or their keep-out areas, this includes films and privacy screens. Accessories that allow the Apple device to slide around must not obstruct any sensors.

3.4 Taptic Engine

Accessories should not cause substantial change in the feel of the Apple device's Taptic Engine.

The following Apple devices contain a Taptic Engine:

- iPhone X
- iPhone 8 Plus
- iPhone 8
- iPhone 7 Plus
- iPhone 7
- iPhone 6s Plus
- iPhone 6s

3.5 Magnetic Interference

Cases must not interfere with the Apple device's magnetic compass or rear camera OIS feature if present.

See [Magnetic Interference](#) (page 15) for additional details.

3.6 Home Button / Touch ID Sensor

Accessories must not inhibit use of the Apple device's Home button / Touch ID sensor including features such as Touch ID fingerprint recognition.

Home button / Touch ID sensor keep-outs for Apple devices can be found in [Device Dimensional Drawings](#) (page 89).

Additionally, accessories that overlay the iPhone 8 Plus, iPhone 8, iPhone 7 Plus, and iPhone 7 Home button / Touch ID sensor may cause users to have difficulty using the Home button / Touch ID sensor.

3.7 Camera

The field of view (FOV) of the camera and the illumination provided by the flash are designed for each Apple product camera. It is imperative that manufacturers consult technical specifications released for each product and do not assume these parameters are shared between products.

Images from the camera may be affected by the geometry, color, and surface finish of the accessory openings for camera and applicable flash.

3.7.1 Geometry

The camera lens FOV must not be blocked. Making the accessory opening too small around the camera and flash may block the FOV of the lens and the illumination from the flash. Blocking the FOV may cause vignetting in the image, where one or more corners of the image reproduced are darker than the center. Blocking marginal rays just outside the FOV of the lens may also reduce the sharpness and contrast of the image. Blocking the illumination from the flash may cause haze in the image, which resulting in reduced contrast. See [Device Dimensional Drawings](#) (page 89) for the camera keep-out.

The accessory opening must not be designed in a way that directs stray light into the camera. If the opening is too narrow or too steep, it may reflect light into the camera, washing out the image or adding an unwanted color cast. Adding a chamfer to the accessory opening trim may help to direct stray light away from the camera. Additionally, where the product is equipped with a flash, a narrow or steep opening may reflect light from the accessory opening back into the camera. This may cause the image to appear washed out or contain unwanted

artifacts. Designers should ensure that the mechanical keep-outs outlined in the device dimensional drawings ([Device Dimensional Drawings](#) (page 89)) are maintained with worst-case X-Y placement tolerances to minimize the risk of haze.

3.7.2 Color

Any light reflected from the accessory may pick up the color of the accessory. Black material or black coating may help avoid color bleeding into the camera from an external light source or the flash. The darker the color, the less light may be reflected from the source into the camera.

Note: Apple recommends a semi-gloss black material or coating around the camera and flash opening.

3.7.3 Surface Finish

The flash is a strong source of light and reflections from the camera accessory opening trim should be managed so that they do not reflect back into the camera. Semi-gloss material may direct light away from the camera. Matte or diffuse materials scatter light in all directions and will increase the likelihood that light from the flash or strong light sources in the scene is reflected into the camera.

3.7.4 Image Degradation Examples

Figure 3-7 Sample image degradation by image blocking in ambient condition

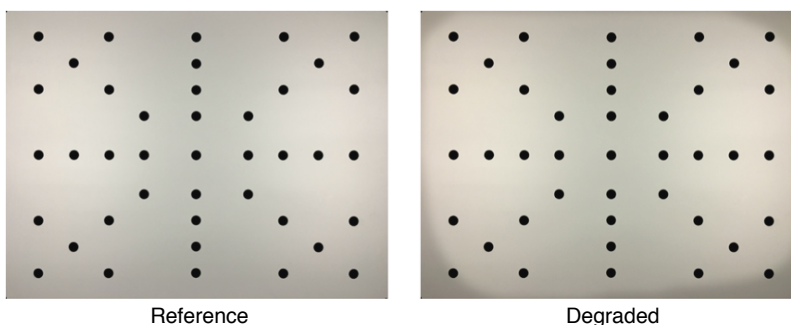

Figure 3-8 Sample image degradation by color shift through accessory with strong color

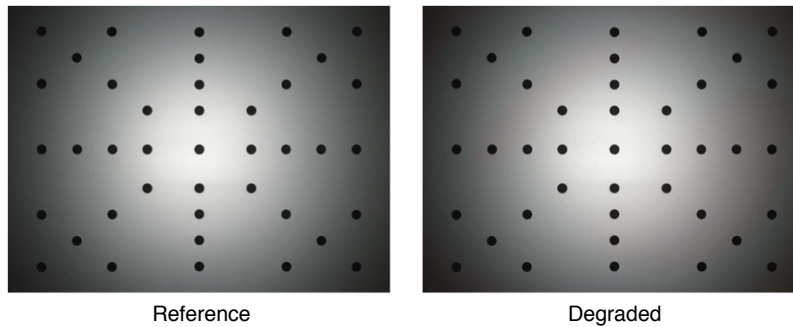
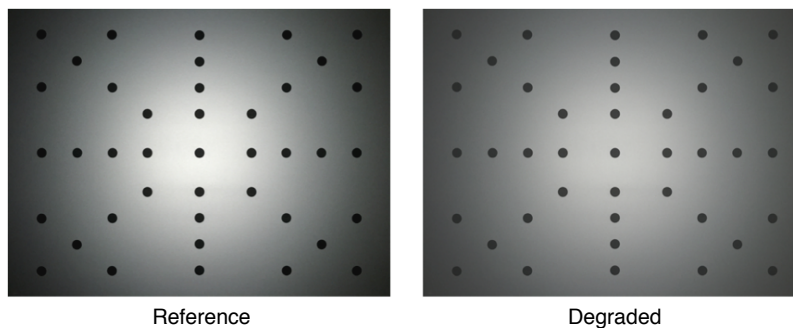

Figure 3-9 Sample image degradation by flash interference



3.8 Reliability

Cases for Apple devices must be tested to verify that they will withstand long-term use under typical use conditions, and that they do not impair or degrade the functionality of the device, damage it or its immediate surroundings, or adversely affect the user.

3.8.1 Device Insertion and Removal

The case must hold the Apple device securely while permitting its easy insertion and removal. The case and the enclosed device must not be damaged by the repeated insertion and removal of the device from the case under conditions representative of long-term use in a variety of environments.

3.8.2 Colorfastness

Any dyes, inks, or coatings in or on the case must not bleed color onto either the device or its user, particularly while the case is in contact with common substances, such as water or sunscreen.

3.9 Environmental

Accessories for Apple devices must comply with applicable environmental regulations in the regions in which such accessories are to be sold, and any applicable substance or material restrictions, including applicable restrictions on the following substances:

- Organic tin compounds, PFOS, PFOA, phthalates, azo dyes, polybrominated biphenyls (PBBs) and PAHs, per requirements of the EU REACH regulation EC 1907/2006.
- Nickel leach rate on surfaces in prolonged skin contact, per requirements of the EU REACH regulation EC 1907/2006.
- Cadmium, lead, hexavalent chromium, and nickel, per requirements of EU Directive 2009/48/EC.
- Natural rubber latex, per requirements of EU Directive EC 93/42/EEC.
- Dimethylfumarate (DMFu), per requirements of EU Regulation 412/2012.
- pH and Formaldehyde, per requirements of China GB 18401 for textiles and China GB 20400 for leather.
- Endangered species of flora and fauna in products or packaging (US Lacey Act).
- Polybrominated diphenyl ethers (PBDE).

3.10 Test Procedures

3.10.1 Required Apple Device Models

Case testing procedures vary depending on the Apple device they enclose.

3.10.1.1 iPhone X

Table 3-1 iPhone X Case Testing Matrix

Test	Using	Notes
Product Design (page 32)	iPhone X	
Taptic Engine (page 34)	iPhone X	
Acoustics (page 36)	iPhone X	

3.10.1.2 iPhone 8 Plus/iPhone 7 Plus

Table 3-2 iPhone 8 Plus/iPhone 7 Plus Case Testing Matrix

Test	Using	Notes
Product Design (page 32)	iPhone 8 Plus and iPhone 7 Plus	
Taptic Engine (page 34)	iPhone 8 Plus and iPhone 7 Plus	
Home Button / Touch ID Sensor Overlays (page 35)	iPhone 8 Plus and iPhone 7 Plus	

Test	Using	Notes
Acoustics (page 36)	iPhone 8 Plus and iPhone 7 Plus	

It is not possible for a case to claim compatibility with only the iPhone 8 Plus or only the iPhone 7 Plus.

3.10.1.3 iPhone 8/iPhone 7

Table 3-3 iPhone 8/iPhone 7 Case Testing Matrix

Test	Using	Notes
Product Design (page 32)	iPhone 8 and iPhone 7	
Taptic Engine (page 34)	iPhone 8 and iPhone 7	
Home Button / Touch ID Sensor Overlays (page 35)	iPhone 8 and iPhone 7	
Acoustics (page 36)	iPhone 8 and iPhone 7	

It is not possible for a case to claim compatibility with only the iPhone 8 or only the iPhone 7.

3.10.1.4 iPhone 6s Plus/iPhone 6 Plus

Table 3-4 iPhone 6s Plus/iPhone 6 Plus Case Testing Matrix

Test	Using	Notes
Product Design (page 32)	iPhone 6s Plus and iPhone 6 Plus	
Taptic Engine (page 34)	iPhone 6s Plus	

It is not possible for a case to claim compatibility with only the iPhone 6s Plus or only the iPhone 6 Plus.

3.10.1.5 iPhone 6s/iPhone 6

Table 3-5 iPhone 6s/iPhone 6 Case Testing Matrix

Test	Using	Notes
Product Design (page 32)	iPhone 6s and iPhone 6	
Taptic Engine (page 34)	iPhone 6s	

It is not possible for a case to claim compatibility with only the iPhone 6s or only the iPhone 6.

3.10.1.6 iPhone 5/iPhone 5s/iPhone SE

Table 3-6 iPhone 5/iPhone 5s/iPhone SE Case Testing Matrix

Test	Using	Notes
Product Design (page 32)	iPhone SE	

It is not possible for a case to claim compatibility with only the iPhone 5 or only the iPhone 5s or only the iPhone SE.

3.10.1.7 iPhone 5c

Table 3-7 iPhone 5c Case Testing Matrix

Test	Using	Notes
Product Design (page 32)	iPhone 5c	

3.10.1.8 iPad Pro (10.5-inch)

Table 3-8 iPad Pro (10.5-inch) Case Testing Matrix

Test	Using	Notes
Product Design (page 32)	iPad Pro (10.5-inch)	

3.10.1.9 iPad Pro (12.9-inch) 2nd Generation

Table 3-9 iPad Pro (12.9-inch) 2nd Generation Case Testing Matrix

Test	Using	Notes
Product Design (page 32)	iPad Pro (12.9-inch) 2nd Generation	

3.10.1.10 iPad (5th and 6th generation)

Table 3-10 iPad (5th and 6th generation) Case Testing Matrix

Test	Using	Notes
Product Design (page 32)	iPad (5th generation) or iPad (6th generation)	

3.10.1.11 iPad Pro (9.7-inch)

Table 3-11 iPad Pro (9.7-inch) Case Testing Matrix

Test	Using	Notes
Product Design (page 32)	iPad Pro (9.7-inch)	

3.10.1.12 iPad Pro (12.9-inch) 1st Generation

Table 3-12 iPad Pro (12.9-inch) 1st Generation Case Testing Matrix

Test	Using	Notes
Product Design (page 32)	iPad Pro (12.9-inch) 1st Generation	

3.10.1.13 iPad mini 4

Table 3-13 iPad mini 4 Case Testing Matrix

Test	Using	Notes
Product Design (page 32)	iPad mini 4	

3.10.1.14 iPad mini/iPad mini 2/iPad mini 3

Table 3-14 iPad mini/iPad mini 2/iPad mini 3 Case Testing Matrix

Test	Using	Notes
Product Design (page 32)	iPad mini 3	

It is not possible for a case to claim compatibility with only the iPad mini or only the iPad mini 2 or only the iPad mini 3.

3.10.1.15 iPad Air 2

Table 3-15 iPad Air 2 Case Testing Matrix

Test	Using	Notes
Product Design (page 32)	iPad Air 2	

3.10.1.16 iPad Air

Table 3-16 iPad Air Case Testing Matrix

Test	Using	Notes
Product Design (page 32)	iPad Air	

3.10.1.17 iPad (4th generation)

Table 3-17 iPad (4th generation) Case Testing Matrix

Test	Using	Notes
Product Design (page 32)	iPad (4th generation)	

3.10.1.18 iPod touch (5th generation)/iPod touch (6th generation)

Table 3-18 iPod touch (5th generation)/iPod touch (6th generation) Case Testing Matrix

Test	Using	Notes
Product Design (page 32)	iPod touch (6th generation)	

It is not possible for a case to claim compatibility with only the iPod touch (5th generation) or only the iPod touch (6th generation).

3.10.2 Product Design

3.10.2.1 Equipment

- Apple device.
- Apple Lightning Digital AV Adapter
- Vernier calipers
- 0.85 mm plastic feeler gauge
- EarPods with 3.5 mm Headphone Plug
- Touchscreen test block (provided by Apple)

3.10.2.2 Procedure

1. Insert the Apple device into the case.
2. Verify that the Apple device completely fits inside the case. The Apple device must not be loose.
3. Verify that all buttons are accessible.
4. Inspect for button feel. The buttons must not be too hard to press or take a lot of effort to press.
5. For Apple devices that have an Apple Lightning connector:
 - a. Insert the Apple Lightning Digital AV Adapter into the Lightning receptacle and verify that it fits.
 - b. Using vernier calipers, measure the Lightning connector opening on the case. Verify that the opening is measured to be at least 12.05 mm by 6.30 mm.
6. For Apple devices that have a 3.5 mm headset jack:
 - a. Insert EarPods with 3.5 mm Headphone Plug into the headset jack of the Apple device and verify it fits.
 - b. Using vernier calipers, measure the headset jack opening on the case. Verify that the opening is measured to be at least 6 mm in diameter and no more than 14 mm deep.
7. For Apple devices with Touch ID, use vernier calipers to verify that the case is at least 2 mm away from the Touch ID sensor.

- Verify that the case is always proud of the feeler gauge when the gauge is placed at each corner of the Apple device. See [Figure 3-10](#) (page 33).

Figure 3-10 Apple device proudness test

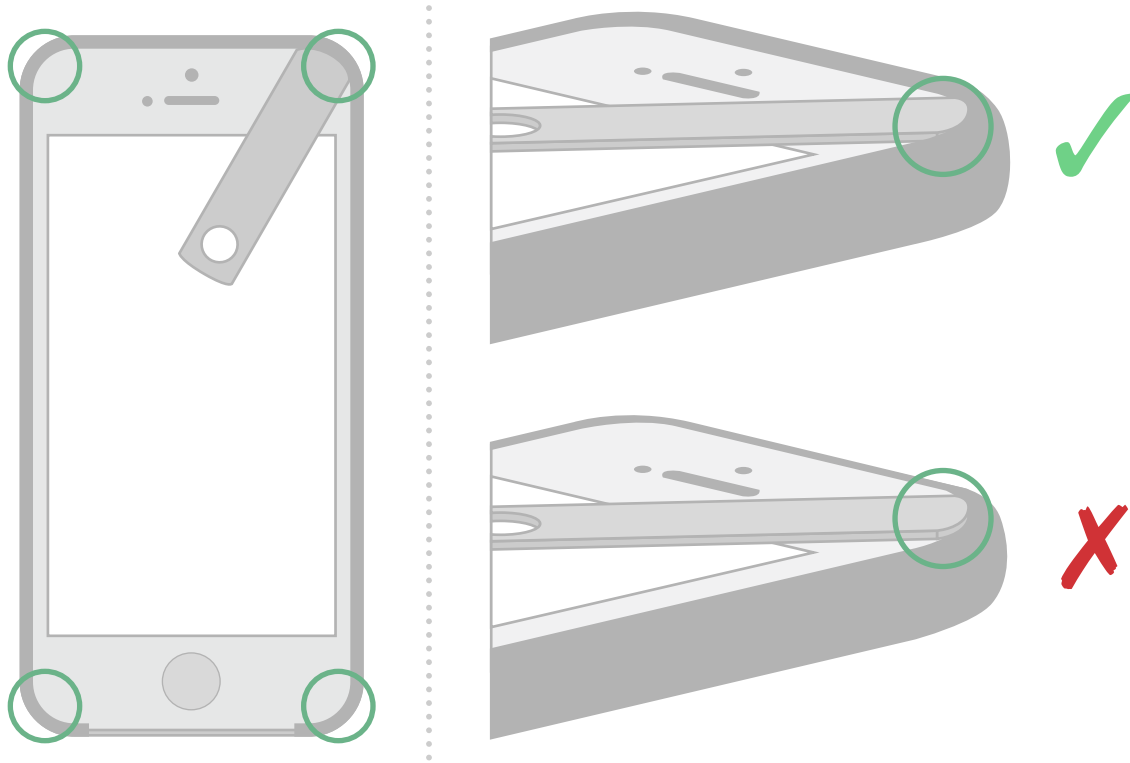

- Set the Apple device flat on its face (screen facing down).
- Roll the device towards any side that is not enclosed by the case until the gap between the Apple device's exposed glass and flat surface is smallest.
- Verify that the feeler gauge fits into the gap between the Apple device's exposed glass and flat surface.

Figure 3-11 Apple device gap test

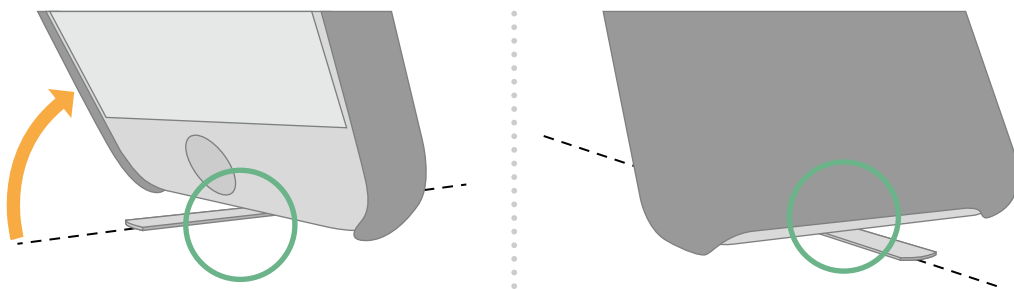

12. Place the touchscreen test block onto the touchscreen of the Apple device. Verify the test block is sitting flush on the touchscreen.

Figure 3-12 Apple device touchscreen keep-out test

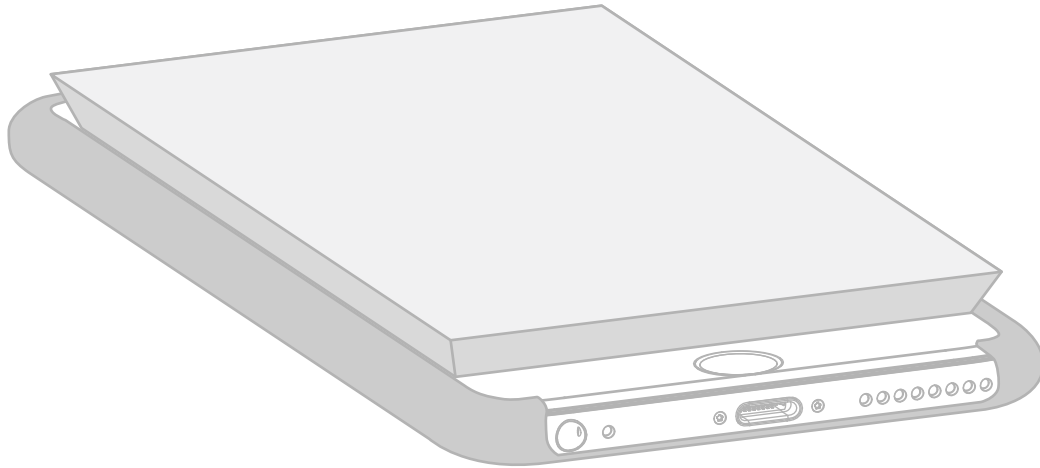

13. If the case has an overlay, verify that there are no air gaps introduced between it and the touchscreen.

3.10.3 Taptic Engine

3.10.3.1 Equipment

- Two Apple devices A and B, same model
- Table

3.10.3.2 Procedure

1. Attach the case to Apple device B
2. Place Apple device A on top of the table.
3. Place Apple device B on top of the table next to Apple device A.
4. Compare the Taptic Engine feedback between Apple device A and Apple device B for each of the following tasks:
 - a. Go to: Settings ->Sound & Haptics, set "Vibrate on Silent"to the on position.
 - b. Toggle the Ring/Silent switch.
 - c. Connect a charger to both Apple devices.
 - d. Go to: Settings ->Notifications ->Phone ->Sounds, select Reflection (Default).
 - e. Go to: Settings ->Notifications ->Messages ->Sounds, select Note (Default).
 - f. Go to the Home screen.
 - g. Trigger a Quick Actions menu by applying pressure to the Settings app. Continue applying pressure.
 - h. Slide your finger across the Quick Actions menu and release when Wi-Fi is selected.

- i. Go to the Home screen.
- j. Apply pressure to the Home app.
- k. Go to: Clock app and select Timer on the bottom right.
- l. Scroll through the hour and minutes.

For Apple devices that have a Home button, perform the following tasks:

- a. Go to: Settings ->General ->Home Button, tap option 2.
 - b. Press the Home button.
5. Repeat the above tasks while holding Apple device A in the left hand and Apple device B in the right hand.

3.10.3.3 Pass/Fail Criteria

The case does not cause substantial change in the feel of the Apple device's Taptic Engine.

3.10.4 Home Button / Touch ID Sensor Overlays

This test procedure is applicable to all iPhone 8 Plus, iPhone 8, iPhone 7 Plus or iPhone 7 accessories that overlay the Home button or the Touch ID sensor.

3.10.4.1 Equipment

- Nitrile gloves (e.g. Ansell TNT Blue)
- Ethyl alcohol hand sanitizer (e.g. Purell)
- Scissors

3.10.4.2 Procedure

1. Cut off a square of material from the nitrile glove's wrist portion.
2. Install the accessory onto the Apple device.
3. Press the sleep/wake or side button to place the Apple device into a sleep state (display off).
4. Place the square of nitrile glove material over the Apple device's Home button / Touch ID sensor with the glove's outer side facing away from the Apple device.
5. Apply a small amount of hand sanitizer (approximately dime-sized) to the nitrile over the Home button / Touch ID sensor.
6. Repeat the following steps 10 times:
 - a. Press the Home button / Touch ID sensor with a thumb.
 - b. Verify that the Apple device wakes (display on).
 - c. Press the sleep/wake or side button to place the Apple device into a sleep state (display off).
7. Repeat the following steps 10 times:
 - a. Press the Home button / Touch ID sensor with an index finger.
 - b. Verify that the Apple device wakes (display on).
 - c. Press the sleep/wake or side button to place the Apple device into a sleep state (display off).

3.10.4.3 Pass/Fail Criteria

The Apple device must wake every time the Home button / Touch ID sensor is pressed.

3.10.5 Acoustics

The following test procedures apply to Apple devices with a built in speaker and/or microphone.

3.10.5.1 Speakerphone Call

This procedure evaluates the impact of a case on the speakerphone performance of an Apple device.

3.10.5.1.1 Equipment and Test Setup

This procedure requires two operators in separate quiet rooms.

Room A:

- Operator A
- The Apple device (with cellular service) used to evaluate the case
 - The Apple device should have at least two out of five bars of cellular reception within the room.

Room B:

- Operator B
- Landline speakerphone
- Digital audio recorder (e.g., an Apple device with the Voice Memo app)

3.10.5.1.2 Pass/Fail Criteria

There are two categories of failure for this procedure:

- Echo: If Operator B hears their own voice from the landline.
- Double Talk: If Operator B hears Operator A inconsistently.

The pass/fail threshold for these two categories should be established by performing the test procedure using:

- The Apple device (without the case) as a reference.

There should be no perceivable difference between the reference and the test conducted with the case on the Apple device.

3.10.5.1.3 Procedure

1. Operator A: Use the Apple device (without a case) in Room A to call the landline phone in Room B.

2. Operator A: Place the Apple device in speakerphone mode.
3. Operator B: Answer the call with the landline phone in Room B.
4. Operator B: Place the landline phone in speakerphone mode.
5. Operator A and B: Simultaneously recite the following phrases to evaluate the call quality:
 - a. The birch canoe slid on the smooth planks.
 - b. Glue the sheet to the dark blue background.
 - c. It's easy to tell the depth of a well.
 - d. These days a chicken leg is a rare dish.
 - e. Rice is often served in round bowls.
 - f. The juice of lemons makes fine punch.
 - g. The box was thrown beside the parked truck.
 - h. The hogs were fed chopped corn and garbage.
 - i. Four hours of steady work faced us.
 - j. Large size in stockings is hard to sell.
6. Operator B: Evaluate the call. Ensure that the call is clear when there is no case on the Apple device.
7. Operator A: Place the case on the Apple device.
8. Operator B: Start audio recording using a digital audio recorder.
9. Operator A: State the test date and identify the manufacturer name, product name, and a unique identifier (UID) for case (production run name, design version, etc.).
10. Operator A and B: Simultaneously recite the same phrases as above.
11. Operator B: Stop audio recording.
12. Operator B: Evaluate the recording against the pass/fail criteria, see [Pass/Fail Criteria](#) (page 36).

Note: The phrases used for this test procedure are from "IEEE Recommended Practice for Speech Quality Measurements," in *IEEE Transactions on Audio and Electroacoustics*, vol. 17, no. 3, pp. 225-246, September 1969.

4. Covers

This chapter is applicable to accessories that cover Apple device displays.

4.1 Magnetic Interference

Accessory covers must not interfere with the Apple device's magnetic compass or rear camera OIS feature if present.

See [Magnetic Interference](#) (page 15) for additional details.

4.2 Smart Covers

Dimensional drawings indicating magnet and Hall effect sensor locations are available for the following Apple devices:

- [iPad Pro \(10.5-inch\) Magnet/Hall Effect Sensors](#) (page 105)
- [iPad Pro \(12.9-inch\) 2nd Generation Magnet/Hall Effect Sensors](#) (page 109)
- [iPad \(5th and 6th generation\) Magnet/Hall Effect Sensors](#) (page 112)
- [iPad Pro \(9.7-inch\) Magnet/Hall Effect Sensors](#) (page 116)
- [iPad Pro \(12.9-inch\) 1st Generation Magnet/Hall Effect Sensors](#) (page 120)

5. Screen Overlays

The touch interface in an Apple device senses the presence of one or more fingers on its surface. Any material between the surface and the user's hand, even a very thin sheet of plastic, may affect the performance of the touch interface.

5.1 Product Design

The screen overlay thickness must not exceed 0.1 mm for the following devices:

- iPad (6th generation)
- iPad Pro (10.5-inch)
- iPad Pro (12.9-inch) 2nd Generation
- iPad Pro (9.7-inch)
- iPad Pro (12.9-inch) 1st Generation

The screen overlay thickness must not exceed 0.3 mm for all other Apple devices.

Additionally, screen overlays must not:

- Introduce air gaps between the touchscreen and overlay.
- Be electrically conductive.

5.2 Edge Swipe Gestures

Users must be able to easily use iOS edge swipe gestures even if a screen overlay is present.

Examples of such gestures include, but are not limited to:

- Bringing up Control Center or Notification Center.
- Swiping 'back' from apps that use edge swipe gestures, such as Messages.

5.3 Edge Press Gestures

Users must be able to easily use iOS edge press gestures even if a screen overlay is present. Apple devices that support the 3D Touch feature, such as iPhone X, iPhone 8 Plus, iPhone 8, iPhone 7 Plus, iPhone 7, iPhone 6s Plus or iPhone 6s, are all capable of edge press gestures.

An edge press gesture is used to bring up the task switcher in iOS 9.0 and later.

6. Camera Attachments

This chapter is applicable to accessories that intentionally alter the images captured by Apple device cameras.

6.1 Magnetic Interference

Accessory camera attachments must not interfere with the Apple device's magnetic compass or rear camera OIS feature if present.

See [Magnetic Interference](#) (page 15) for additional details.

7. Apple AirPods Attachments

This chapter is applicable to accessories that attach to Apple AirPods.

7.1 Interference

Accessory AirPods attachments must not interfere with the keep-out areas specified in [Figure 7-1](#) (page 43).

Figure 7-1 AirPods Keep-Out Drawing

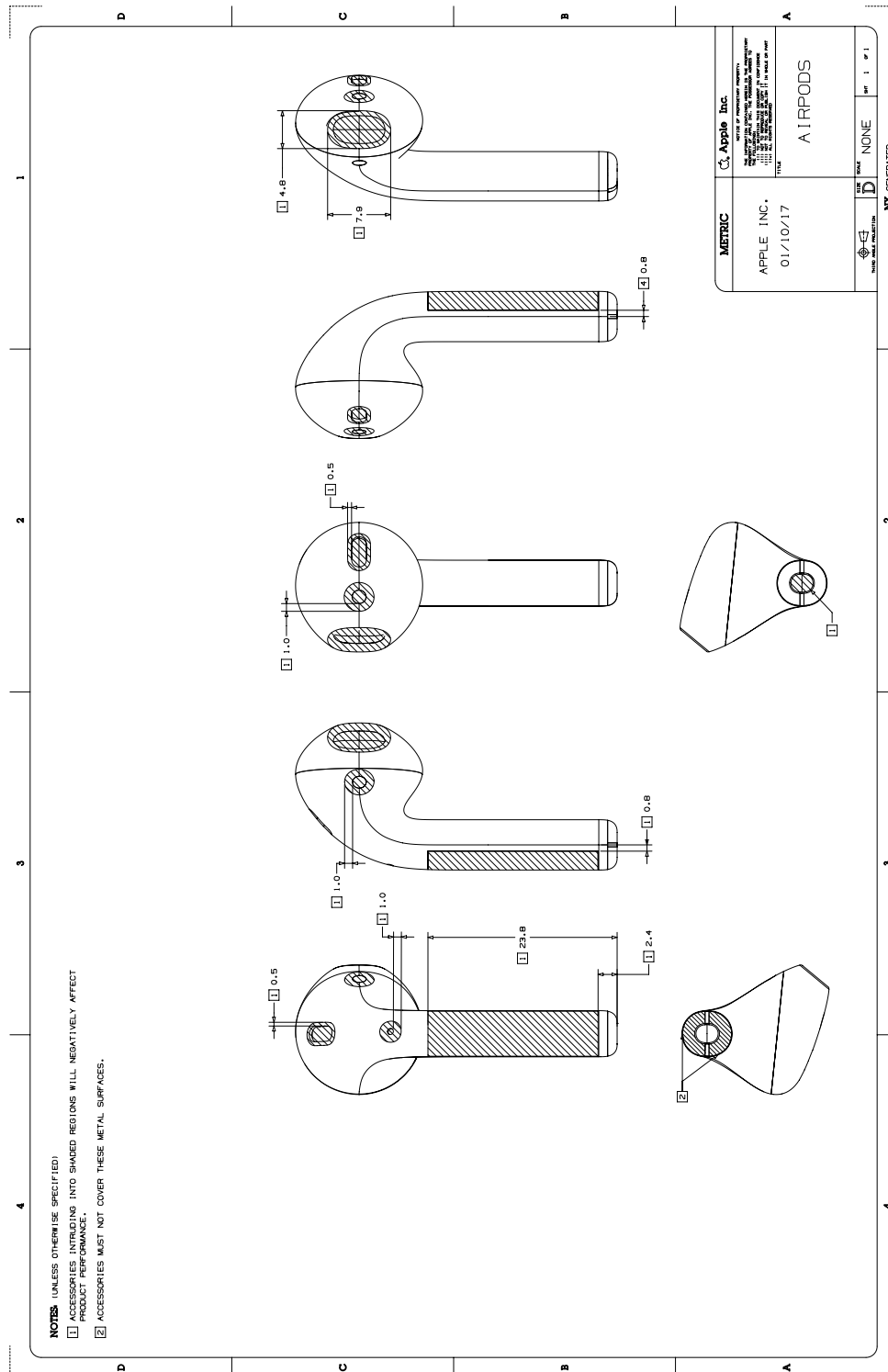

Bluetooth

8. Bluetooth Introduction

To be compatible with Apple products, both current and future, Bluetooth accessories should follow the guidelines in this specification. An Apple product may make feature availability contingent on the Bluetooth accessory following these specifications.

8.1 Apple Bluetooth Development Mailing List

Questions or comments regarding accessory development for Apple products can be posted to the Apple mailing list for Bluetooth development, <mailto:bluetooth-dev@lists.apple.com>. See <http://lists.apple.com/mailman/listinfo/bluetooth-dev> to join the mailing list.

Engineers on the Apple Bluetooth development team monitor this mailing list and will try to answer your questions. Apple recommends searching the archives to see if a topic has already been discussed before starting a new thread.

9. Bluetooth

Accessories that integrate Bluetooth technology must comply with the requirements stated in this chapter.

Every accessory that is compatible with an Apple product must support the *Bluetooth Core Specification* Version 2.1 + EDR or higher. This specification introduced the important security feature Secure Simple Pairing as well as Extended Inquiry Response.

9.1 Enhanced Data Rate

The Enhanced Data Rate (EDR) feature introduced in the *Bluetooth 2.0* specification enables accessories to communicate more efficiently. Every accessory must use EDR for the following reasons:

- It provides higher data rates compared to Basic Data Rate (BDR).
- It communicates more efficiently, transferring more data bits per unit of time.
- It reduces the power consumption used per bit transferred.
- It improves coexistence with Wi-Fi and other connected Bluetooth devices because it frees up more air time.
- It improves performance in multipoint configurations.

9.2 Adaptive Frequency Hopping

The Adaptive Frequency Hopping (AFH) feature introduced in the *Bluetooth 1.2* specification improves coexistence with Wi-Fi and other connected Bluetooth devices. Every accessory must use AFH.

9.3 Sniff Mode for Low Power Consumption

Minimizing power consumption is critical for all mobile devices. Therefore, every accessory that is compatible with an Apple product:

- Must support and should request Bluetooth sniff mode.
- Must accept requests for sniff mode and support all valid parameters listed in the Bluetooth specification.
- Must support a sniff interval of 15 ms.
- Should use the following recommended sniff mode values:

- Max Interval: 15 ms
- Min Interval: 15 ms
- Sniff Attempt: 1
- Sniff Timeout: 0
- Must not renegotiate sniff after being established.
- Must support sniff subrating.

Accessories that are compatible with Apple products should also use sniff mode as much as possible, especially when there is little or no data being transmitted over the Bluetooth link. Besides its power consumption advantages, sniff mode enables better antenna sharing with Wi-Fi.

The sniff mode parameters are specific to the usage model and Bluetooth profile. The Apple product expects the accessory to request sniff mode with appropriate parameters for a specific usage. If the accessory does not send such a request, the Apple product may send a sniff mode request. When the Apple product sends a request for sniff mode, the remote device must accept the request and its parameters without negotiation.

If the accessory sets the sniff mode parameters, the accessory must set the sniff interval to less than a third of the Bluetooth baseband Link Supervision Timeout, see [Link Supervision Timeout](#) (page 49). This makes the Bluetooth link less susceptible to interference. To improve link robustness, the accessory should use a shorter sniff interval instead of multiple sniff attempts.

Links with a sniff interval of 1 second or more make the slave device open up a large correlation window, which has to be taken into account when calculating the number of sniff attempts. With sniff intervals shorter than 1 second, multiple sniff attempts can improve link robustness but will increase power consumption.

9.4 Role and Topology Management

Every accessory that is compatible with an Apple product must:

- Accept a request for Role Switch from an Apple product.
- Continue with the connection when the Apple product rejects a request for Role Switch.

In a Bluetooth connection, one device is the master and the other the slave. The master can have multiple slaves, thus forming a piconet. The master can also be a slave to another master, creating a scatternet.

Such a scenario creates complications since the device has to alternate between the two piconets and thus wastes valuable bandwidth. Managing the topology of the network is therefore important for maximum performance. The Apple product may request a Role Switch, depending on its current topology, and the remote device must accept the request. The Apple product may also reject a request for a Role Switch because of topology concerns. Having a suboptimal topology may degrade the audio quality and the user's experience.

The accessory should avoid requesting to be the master as the Apple product will need to be the master in more frequently occurring scenarios. Accessories that always insist on being the master may impact the overall user experience.

Accessories that connect to multiple Apple products simultaneously must support creating a scatternet.

9.5 Extended Inquiry Response

Every accessory that is compatible with an Apple product must provide the following information in its Extended Inquiry Response packet:

- The Local Name of the accessory (Complete or Shortened).
- The TX Power Level.

During the Bluetooth discovery process, the Apple product prefers to display the Friendly Name of discovered accessories. Before the 2.1 version of the Bluetooth specification the Apple product would have to set up a connection to the accessory and do a Remote Name Request, which takes power, antenna time, and user's time. The Extended Inquiry Response feature, introduced in Bluetooth 2.1, lets an accessory send its Local Name and other information as part of the Inquiry Response and thereby increase the speed and efficiency of the discovery process.

The Local Name should match the accessory's markings and packaging and not contain ':' or ';'.

9.6 Secure Simple Pairing

Every accessory that is compatible with an Apple product must:

- Use Secure Simple Pairing.
- Use the Numerical Comparison method if it has a display and input device supporting it.

Secure Simple Pairing greatly increases security and is a mandatory security feature introduced in the Bluetooth 2.1 specification. To protect against a man-in-the-middle attack, the Numerical Comparison association model should be used whenever feasible. See Volume 1, Section 5.4 in the *Bluetooth Core Specification, Version 2.1 + EDR*.

9.7 Pairing Button

If the accessory has a dedicated pairing button and it is labeled, it should use official Bluetooth branding. See <https://www.bluetooth.com/marketing-branding/brand-best-practices-guidelines>.

9.8 Class of Device (CoD)

Apple products use the accessory's Class of Device for UI purposes or to configure specific features.

Every accessory that is compatible with an Apple product must accurately set its Class of Device using the Bluetooth SIG defined Major Device Class and Minor Device Class. See Volume 3, Part C, Section 3.2.4 in the *Bluetooth Core Specification, Version 5.0*.

For example, an audio/video accessory intended to operate in a vehicle should set Major Device Class to *audio/video* and Minor Device Class to *car-audio*.

9.9 Link Supervision Timeout

The link supervision timeout is used to detect link loss between the accessory and the Apple device.

The accessory must set the link supervision timeout to 2 seconds or greater when it is the master to account for the unpredictable nature of RF signals as well as the Apple device's need to service other concurrent wireless systems.

9.10 Delay Reporting

Apple devices (as of iOS 8.2) support the Delay Reporting commands as specified in the Bluetooth *Audio/Video Distribution Transport Protocol, Version 1.3*. Accessories should provide this information as it is used to improve audio/video synchronization for video playback. Accessories should not report a delay of more than 1000 ms and should not update the delay more than 1 time per second.

9.11 Profiles

The Apple knowledge base article <https://support.apple.com/kb/ht3647> provides a complete list of the Bluetooth profiles that certain Apple devices support. The Bluetooth specifications are the starting point for designing accessories that are compatible with these products. The following sections add information and requirements for some profiles, which can help accessory developers achieve superior results.

9.11.1 Device ID Profile (DID)

Every accessory that is compatible with an Apple product must:

- Support the Bluetooth Device ID Profile, version 1.3 or higher.

- Use the company identifier from the Assigned Numbers specification assigned by the Bluetooth SIG as its Vendor ID value (VID). See <http://www.bluetooth.org/Technical/AssignedNumbers/identifiers.htm> (requires login). Bluetooth HID Profile accessories may use a VID assigned by the USB Implementers Forum (USB-IF at <http://www.usb.org>) if the manufacturer does not have a Bluetooth SIG company identifier.
- Use its VID value for the end product manufacturer.
- Not use the Company ID assigned to Apple by the Bluetooth SIG or the Vendor ID assigned to Apple by the USB Implementers Forum.
- Use the Vendor ID Source field to identify which organization assigned the value used in Vendor ID field value. See Section 5.6 of the *Bluetooth Device ID Profile Specification*.
- Use a ProductID value that uniquely identifies the product.
- Use a Version value that uniquely identifies the software version.

The Device ID record lets the Apple product identify the implementation of the remote accessory. This is valuable information and can be used to bridge alternate interpretations of the Bluetooth specification when communicating with a remote accessory. Therefore it is important that the information in the Device ID record uniquely identify the implementation.

In the case of Bluetooth car kit devices, for instance, the same car kit might go into two different car models. Ideally the two car kits should have different ProductIDs. However, it is acceptable for them to have the same ProductID as long as they have identical hardware, software, and features. If the implementations differ at all, they should have different ProductIDs. The accessory can also use a secondary Device ID record to uniquely identify the product ID or model number.

9.11.2 Service Discovery Protocol (SDP)

To facilitate caching of Service Discovery Protocol (SDP) service records, every accessory that is compatible with an Apple product must:

- Support the ServiceDiscoveryServer Service Class.
- Support the ServiceDatabaseState attribute.
 - The attribute's value must change whenever any SDP service record or attributes within a record are added, removed, or modified.
 - The attribute's value must not change based on RFCOMM channel protocol parameters since Apple devices query these values separately at connection time.

9.11.3 Hands-Free Profile (HFP)

Every accessory that is compatible with an Apple product and supports the Handsfree Profile should meet the requirements of the *Bluetooth Hands-Free Profile Specification*, Version 1.5 or higher. Additional Apple requirements are specified in this section.

Remote accessories can use the Bluetooth *Hands-Free Profile* for phone communications. To achieve the best user experience, the remote accessory should support the following features, which are optional in the Bluetooth specification.

9.11.3.1 Remote Audio Volume Control

Every accessory that is compatible with an Apple product and supports HFP should:

- Support Remote Audio Volume Control so the speaker volume on the Hands-Free accessory can be controlled from the Apple product as described in Section 4.28 in the *Bluetooth Hands-Free Profile Specification* version 1.5.
- Set the Remote volume control bit in the Supported Features bitmap sent with the AT+BRSF= command.

In some situations it is easier for the user to control the output volume through the Apple product instead of directly on the remote accessory. For example, a passenger (or-if the car is parked-the driver) in a car could use the volume slider on the phone to control the audio volume. Volume control synchronization is outlined in Section 4.48.2 in the *Bluetooth Hands-Free Profile Specification* version 1.5.

9.11.3.2 Indicator Event Reporting

Every accessory that is compatible with an Apple product and supports HFP should use indicator events reporting and not perform repetitive polling of status.

Apple products support all mandatory and optional indicators specified in HFP version 1.5 (service, call, callsetup, callheld, signal, roam, battchg). To minimize unnecessary polling of status using the AT+CIND? command, the remote accessory should enable indicator events reporting by sending an AT+CMER command. The Apple product will then send a +CIEV event when there is a change in status of an indicator. The remote accessory should request the initial status using the AT+CIND=? and AT+CIND? commands, according to the HFP specification.

9.11.3.3 Voice Recognition Activation

Every accessory that is compatible with an Apple product and supports HFP must:

- Support Voice Recognition Activation, both AG and HF initiated as described in Section 4.25 in the *Bluetooth Hands-Free Profile Specification* version 1.5.
- Set the Voice Recognition Activation bit in the "SupportedFeatures"bitmap sent with the AT+BRSF= command.

Apple products support voice recognition initiated by remote (Hands-Free) accessories and iOS (Audio Gateway) accessories.

9.11.3.4 Echo Cancellation and Noise Reduction

When echo cancellation and noise reduction are performed locally on a Hands-Free accessory, it should turn off echo cancellation and noise reduction on the Apple product by sending an AT+NREC command, as described in Section 4.24 in the *Bluetooth Hands-Free Profile Specification* version 1.5.

Apple products support echo cancellation and noise reduction; these features are active by default. If a Hands-Free accessory also does echo cancellation and noise reduction it needs to turn these features off on the Apple product (the Audio Gateway). This avoids unnecessary degradation of audio quality due to double audio processing.

9.11.3.5 In-Band Ringing

Every accessory that is compatible with an Apple product and supports HFP should also support In-Band Ringing as specified in Section 4.13.1 in the *Bluetooth Hands-Free Profile Specification* version 1.5. If the user sets a ring tone on the Apple product, the same ring tone should sound on the hands-free accessory.

9.11.3.6 Synchronous Connection

Every accessory that is compatible with an Apple product and supports HFP must:

- Support eSCO parameter set S2 and S3 and accept requests for these settings. See Section 5.6 of the *Bluetooth Hands-Free Profile Specification* version 1.5.
- Request eSCO parameter set S2 or S3 when setting up a Synchronous Connection. Note that eSCO parameter set S1 should not be requested.
- Render audio within 40 ms after the SCO/eSCO connection has been set up.

The eSCO packet types offers retransmission of packets; traditional SCO packets are not retransmitted. This improves audio quality and the user's experience. The eSCO packet types 2-EV3 and 3-EV3 offer a greater time interval between packets, which can improve Wi-Fi performance and allow time for other concurrent Bluetooth connections to send data. Apple strongly recommends the use of 2-EV3 and 3-EV3 packets for SCO connections. Using HV3 packets is highly discouraged. HV3 packets require more link time and does not allow for retransmission of audio packets which impacts the audio performance in presence of RF interference.

9.11.3.7 Wide Band Speech

Every accessory that is compatible with an Apple product and supports HFP should support Wide Band Speech as described in Section 5.74 of the *Bluetooth Hands-Free Profile* specification version 1.6. If Wide Band Speech is supported, it should support the T2 link parameter settings.

All Apple devices running iOS 5 or later support Wide Band Speech. If both the Apple device and the accessory support Wide Band Speech then Wide Band Speech link will be used for eSCO connection for use cases like cellular calls, FaceTime and Siri.

9.11.4 Message Access Profile (MAP)

Every accessory that is compatible with an Apple product and supports MAP must:

- Support Message Notification as described in Section 4.1 of the *Bluetooth Message Access Profile Specification*, version 1.0.
- Register for notifications immediately after the connection is established, as described in Section 4.5 in the *Message Access Profile Specification*, version 1.0.
- Not expect the TEL property to be present in the originator VCARD (the properties N and FN will be included). See Section 3.1.3 in the *Message Access Profile Specification*, version 1.0.
- Not provide a user interface for sending messages. Apple devices do not support sending messages using MAP.

All Apple devices running iOS 6.0 or later support MAP.

9.11.5 Audio/Video Remote Control Profile (AVRCP)

Every accessory that is compatible with an Apple product and supports the Audio/Video Remote Control Profile should meet the requirements of the *Bluetooth Audio/Video Remote Control Profile Specification*, Version 1.4. Additional Apple requirements are specified in this section.

9.11.5.1 Supported Operations

Apple products support the following operation_IDs in passthrough commands:

- Play
- Stop
- Pause
- Fast Forward
- Rewind
- Forward
- Backward

9.11.5.2 Repeat and Shuffle Modes

Every Apple device supports Repeat and Shuffle modes in the role of an AVRCP target. An AVRCP controller may use `SetPlayerApplicationSettingValue` to set a value on the Apple device and `GetPlayerApplicationSettingValue` to read a value, as described in Sections 6.5.4 and 6.4.3 of the *Bluetooth Audio/Video Remote Control Profile Specification* version 1.4.

9.11.5.3 Notifications

Every accessory that is compatible with an Apple product and supports AVRCP should register for notifications and not perform repetitive polling to determine the status of the Apple product.

Every Apple device supports registering for notifications in the role of an AVRCP Target, as described in Section 6.7 of the *Bluetooth Audio/Video Remote Control Profile Specification* version 1.4. The commands RegisterNotification and GetPlayStatus are supported for these notifications:

- EVENT_PLAYBACK_STATUS_CHANGED
- EVENT_TRACK_CHANGED
- EVENT_NOW_PLAYING_CONTENT_CHANGED
- EVENT_AVAILABLE_PLAYERS_CHANGED
- EVENT_ADDRESSED_PLAYER_CHANGED
- EVENT_VOLUME_CHANGED

9.11.5.4 Play/Pause Button

All accessories that support AVRCP and implement a Play/Pause button must confirm the playback status of the Apple device via AVRCP notifications (see [Notifications](#) (page 54) before sending a Play or Pause command (see [Supported Operations](#) (page 53)). Specifically:

- If the Apple device has notified the accessory that it is paused, pressing the accessory's Play/Pause button should send a Play command.
- If the Apple device has notified the accessory that it is playing, pressing the accessory's Play/Pause button should send a Pause command.
- The accessory should not infer Apple device playback status based on the number of times the Play/Pause button has been pressed.

9.11.5.5 Volume Handling

Every accessory that is compatible with an Apple product and supports AVRCP should support Absolute Volume, as described in Section 6.13 of the *Bluetooth Audio/Video Remote Control Profile Specification* version 1.4.

Every Apple device supports volume handling in the role of AVRCP Controller.

9.11.5.6 Browsing

Every accessory that is compatible with an Apple product and supports Browsing (in controller role) as part of AVRCP must:

- Not try to index or cache the entire library upon connection. The Apple product may contain tens of thousands of media items, each present multiple times in the hierarchy.

- When browsing a specific folder, do not fetch all its items. Only fetch those that are displayed to the user. It may prefetch a few items to improve the responsiveness of the user interface.
- Not reorder items (e.g. alphabetically).
- Not assume UIDs to be statically defined, especially in the root folder. The ordering and UIDs of folders and items may change at any point in future releases.
- Send the `SetBrowsedPlayer` command after receiving an `EVENT_UIDS_CHANGED` notification.
- Not assume that the UID passed to the `PlayItem` command will result in the media player playing that UID.

Currently only the built-in Music app supports browsing. When switching between players, an `EVENT_AVAILABLE_PLAYERS_CHANGED` notification and an `EVENT_ADDRESSED_PLAYER_CHANGED` notification will be generated. The UI then needs to look at the feature bit mask of the listed player to determine whether browsing is currently available.

All Apple devices running iOS 6.0 or later support AVRCP Browsing.

9.11.5.7 iOS App-Provided Metadata

An audio app running on an Apple device may use the iOS Media Player Framework to provide metadata about the current audio stream. The Apple device supplies this metadata to the accessory using AVRCP. For more information, see the `MPNowPlayingInfoCenter` class in Apple Media Player Framework documentation.

9.11.6 Advanced Audio Distribution Profile (A2DP)

See [Advanced Audio Distribution Profile \(A2DP\)](#) (page 66).

9.12 Audio Routing

This section describes how an accessory can differentiate between various audio contents coming from an Apple device and use this information to decide playback behavior.

An accessory can receive audio data from the Apple device via either of two Bluetooth profiles:

- HFP using eSCO channel
- A2DP using ACL channel

The Apple device picks which channel to use depending on how the audio content is used. An audio path created for two way communication (such as phone calls or FaceTime) always uses the HFP (eSCO) route for sending audio data. Music and similar content uses the A2DP route. In the absence of a defined route, audio playback will default to the Apple device.

9.12.1 Audio Data Received via HFP Profile

Most of the audio content sent via HFP (eSCO) routes requires two way communication. Cases where HFP (eSCO) is used include (but are not limited to) cellular calls, FaceTime, and voice mail.

For any audio content that is being received via the HFP (eSCO) route, it is expected that both the speaker and the microphone of the accessory are dedicated to the Bluetooth link and should not handle any other audio content.

9.12.2 Audio Data Received via A2DP Profile

Audio content transferred via A2DP profiles can be broadly classified into two categories:

- Audio content from music, video, or game-like applications.
- System-generated sound for alerts and notifications.

9.12.2.1 Differentiating Audio Content from System Sounds

Music-like content can be differentiated from system sound by adding support for Audio/Video Remote Control Profile (AVRCP) version 1.3 or later. The AVRCP profile allows an accessory to be aware of the audio playback state in the Apple device, using notifications. See [Audio/Video Remote Control Profile \(AVRCP\)](#) (page 53).

When an Apple device initiates audio playback over an A2DP channel for playing music content, an AVRCP notification `EVENT_PLAYBACK_STATUS_CHANGED` is sent to indicate that playback status has changed to play state. See Section 6.7.2 of the *Audio/Video Remote Control Profile* specification, version 1.4. This indicates that audio data via the A2DP profile contains music. When an Apple device initiates audio playback over an A2DP channel for playing system sound, no AVRCP notification is sent.

[Figure 9-1](#) (page 57) and [Figure 9-2](#) (page 57) show the difference between the notifications for music playback and for system sounds.

Figure 9-1 Initiate Audio Playback (e.g. music)

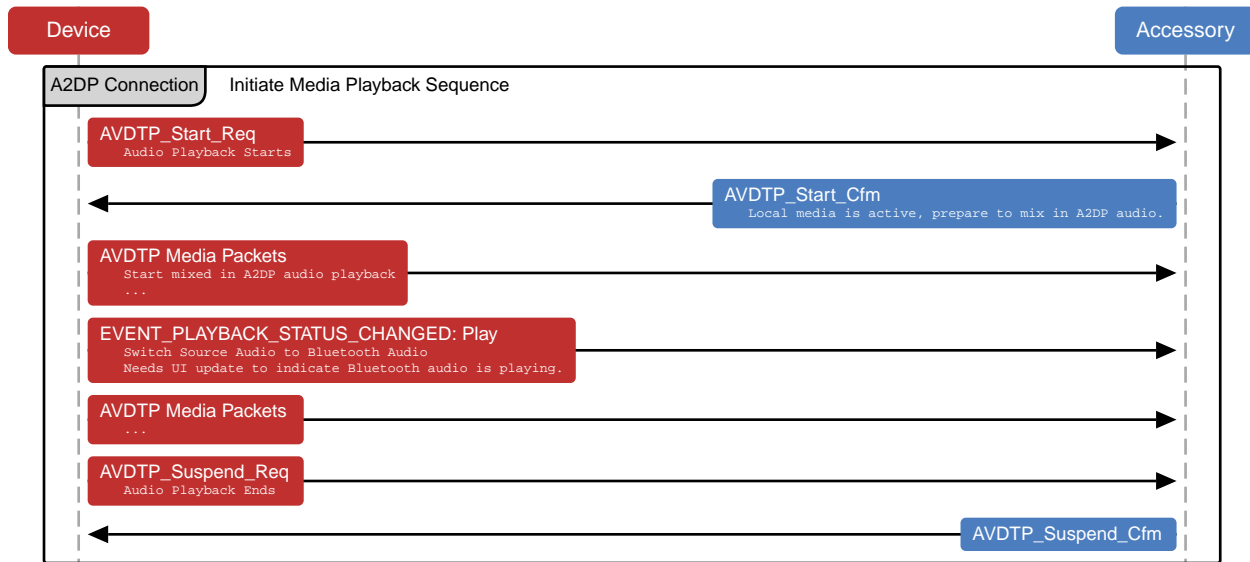
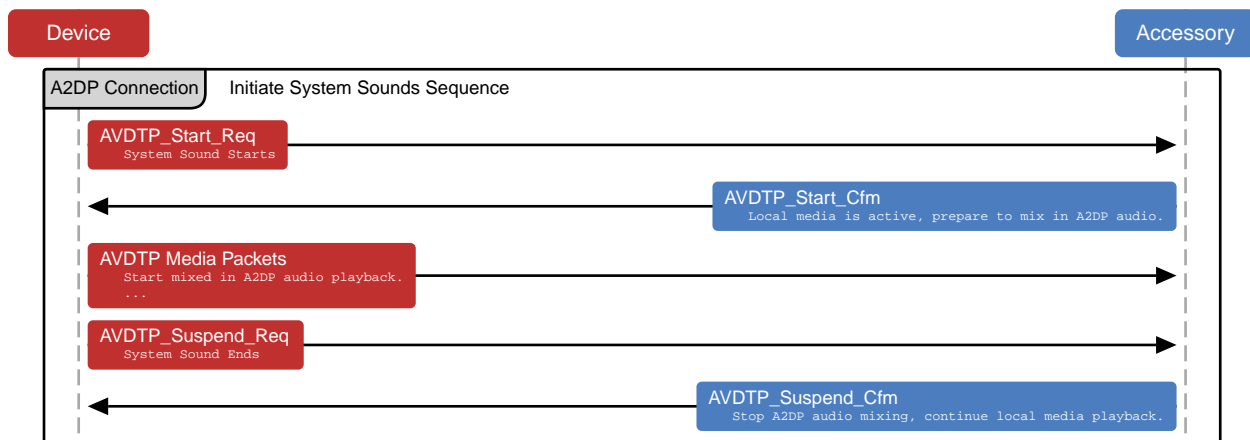

Figure 9-2 Initiate System Sound (e.g. turn-by-turn directions)



9.12.2.2 Expected Audio Routing Behavior for A2DP

The accessory should tune its audio routing behavior based on audio content over the A2DP channel.

If audio data contains music, then it is expected that the accessory speakers are dedicated to audio data coming via the Bluetooth link and any other audio playback is paused. If audio data contains system sound, then it is expected that the accessory can render audio as desired. If the accessory is playing audio from a different source, then system sound data can be mixed with the existing track for playback; it is not necessary to pause existing audio playback on the device.

9.13 HID

When implementing HID over Bluetooth, the accessory:

- Should support Bluetooth HID 1.1.
- Should support sniff mode (see [Sniff Mode for Low Power Consumption](#) (page 46)).
- Should use the following parameters in SDP for sniff subrating:
 - HIDSSRHostMaxLatency - 450 ms (720 slots)
 - HIDSSRHostMinTimeout - 45 ms (72 slots)
- Should use a typical report packet of 22 bytes or less. This is small enough to fit into a DH1 packet with L2CAP and HID header.

10. Bluetooth Low Energy

The *Bluetooth 4.0* specification introduces Bluetooth Low Energy, a wireless technology targeted for accessories with limited battery resources. If Bluetooth Low Energy is supported, the accessory should follow the guidelines in this section.

10.1 Role

The accessory should implement either the Peripheral role as defined in the *Bluetooth 4.0* specification, Volume 3, Part C, Section 2.2.2.3 or the Broadcaster role, as defined in Section 2.2.2.1.

10.2 Advertising Channels

The accessory should advertise on all three advertising channels (37, 38, and 39) at each advertising event. See the *Bluetooth 4.0* specification, Volume 6, Part B, Section 4.4.2.1.

10.3 Advertising PDU

The accessory should use one of the following advertising PDUs:

- ADV_IND
- ADV_NOCONN_IND
- ADV_SCAN_IND

ADV_DIRECT_IND should not be used. See the *Bluetooth 4.0* specification, Volume 6, Part B, Section 2.3.1.

10.4 Advertising Data

The advertising data sent by the accessory should contain at least the following information as described in the *Bluetooth Core Specification Supplement, Part A*:

- Flags
- TX Power Level

- Local Name
- Services

The Local Name should match the accessory's markings and packaging and not contain ':' or ';'.

The accessory may put the Local Name and the TX Power Level data in the SCAN_RSP PDU if, for example, it needs to reduce power consumption or not all of the advertising data fit into the advertising PDU. Note that, depending on its state, the Apple product may not always perform active scanning.

The primary services should always be advertised in the advertising PDU. Secondary services should not be advertised. Services not significant to the primary use case of the accessory may be omitted if space is limited in the Advertising PDU.

The advertising data and the scan response data in the SCAN_RSP PDU should comply with the formatting guidelines in the *Bluetooth 4.0* specification, Volume 3, Part C, Section 18: it starts with a length field, followed by AD Type and AD Data.

10.5 Advertising Interval

The advertising interval of the accessory should be carefully considered, because it affects the time to discovery and connect performance. For a battery-powered accessory, its battery resources should also be considered.

To be discovered by the Apple product, the accessory should first use the recommended advertising interval of 20 ms for at least 30 seconds. If it is not discovered within the initial 30 seconds, Apple recommends using one of the following longer intervals to increase chances of discovery by the Apple product:

- 152.5 ms
- 211.25 ms
- 318.75 ms
- 417.5 ms
- 546.25 ms
- 760 ms
- 852.5 ms
- 1022.5 ms
- 1285 ms

Note: Longer advertising intervals usually result in longer discovery and connect times.

10.6 Connection Parameters

The accessory is responsible for the connection parameters used for the Low Energy connection. The accessory should request connection parameters appropriate for its use case by sending an L2CAP Connection Parameter Update Request at the appropriate time. See the *Bluetooth 4.0* specification, Volume 3, Part A, Section 4.20 for details.

The connection parameter request may be rejected if it does not comply with all of these rules:

- Slave Latency ≤ 30
- 2 seconds \leq connSupervisionTimeout \leq 6 seconds
- Interval Min modulo 15 ms == 0
- Interval Min ≥ 15 ms
- One of the following:
 - Interval Min + 15 ms \leq Interval Max
 - Interval Min == Interval Max == 15 ms
- Interval Max * (Slave Latency + 1) \leq 2 seconds
- Interval Max * (Slave Latency + 1) * 3 < connSupervisionTimeout

Note that if an accessory requests Interval Min == Interval Max == 15 ms, some Apple devices will scale the interval to 30 ms to balance power and performance constraints.

If Bluetooth Low Energy HID is one of the connected services of an accessory, connection interval down to 11.25 ms may be accepted by the Apple product.

The Apple product will not read or use the parameters in the Peripheral Preferred Connection Parameters characteristic. See the *Bluetooth 4.0* specification, Volume 3, Part C, Section 12.5.

10.7 Data Packet Length Extension

Data Packet Length Extension is an enhancement introduced in the *Bluetooth 4.2* specification which increases the maximum data length from 27 to 251. Using a longer per-packet data length improves radio efficiency, greatly increases application data rates, and boosts battery life. See the *Bluetooth 5.0* specification, Volume 6, Part B, Section 4.6.6 for details.

Figure 10-1 Data Packet Length Extension

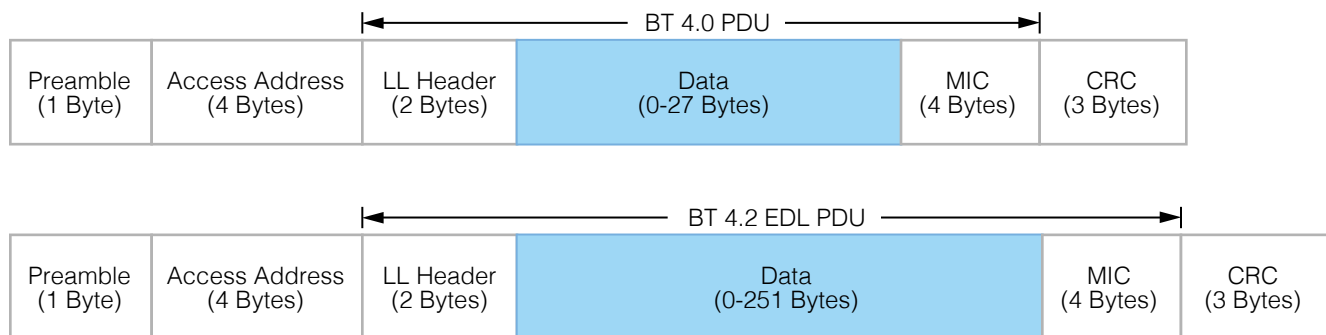

Accessories should support Data Packet Length Extension for best performance with Apple devices.

Apple products operating as master will negotiate optimal data packet lengths based on various factors, such as connection event length, system topology, and protocol.

10.8 Privacy

The accessory should be able to resolve a Resolvable Private Address in all situations. Due to privacy concerns, the Apple product will use a Random Device Address as defined in the *Bluetooth 4.0* specification, Volume 3, Part C, Section 10.8.

10.9 Permissions

The accessory should not require special permissions, such as pairing, authentication, or encryption to discover services and characteristics. It may require special permissions only for access to a characteristic value or a descriptor value. See the *Bluetooth 4.0* specification, Volume 3, Part G, Section 8.1, fifth paragraph.

10.10 Pairing

The accessory should not request pairing until an ATT request is rejected using the Insufficient Authentication error code. See the *Bluetooth 4.0* specification, Volume 3, Part F, Section 4 for details.

If, for security reasons, the accessory requires a bonded relationship with the Central, the Peripheral should reject the ATT request using the Insufficient Authentication error code, as appropriate. As a result, the Apple product may proceed with the necessary security procedures.

Similarly, if the Apple device acts as a Central and a GATT server, it may reject an ATT request using the Insufficient Authentication error code. The accessory should initiate the security procedure for pairing in response.

Pairing may require user authorization depending on Apple product. Once an accessory is paired with an Apple product, it must retain the distributed keys of both central and peripheral for future use. If the pairing is no longer required, the accessory must delete both sets of keys.

10.11 MTU Size

An accessory that supports packet length extension must perform the packet length update procedure before performing the Exchange MTU Request handshake, see [Data Packet Length Extension](#) (page 61).

Apple devices will support and request an MTU size larger than the default during the Exchange MTU Request handshake. See the *Bluetooth 4.0* specification, Volume 3, Part F, Section 3.2.8.

When operating as ATT client, the Apple device will request the optimal MTU size based on factors such as the Bluetooth topology, connection event length, maximum data length, and protocol (GATT or connection-oriented L2CAP).

An accessory operating as ATT server should select an MTU that is equal to or greater than the Apple device's MTU request.

10.12 Services

10.12.1 Generic Access Profile Service

The accessory should implement the Device Name characteristic per the *Bluetooth 4.0* specification, Volume 3, Part C, Section 12.1. The Device Name characteristic should be writeable.

10.12.2 Generic Attribute Profile Service

The accessory must implement the Service Changed characteristic only if the accessory has the ability to change its services during its lifetime.

The Apple product may use the Service Changed characteristic to determine if it can rely on previously read (cached) information from the device. See the *Bluetooth 4.0* specification, Volume 3, Part G, Section 7.1.

10.12.3 Device Information Service

The accessory must implement the Device Information Service. The service UUID for this service should not be advertised in the Advertising Data. The following characteristics should be supported:

- Manufacturer Name String
- Model Number String
- Firmware Revision String
- Software Revision String

10.12.4 Available Services

With iOS 7.0, any Apple device makes Battery Service, Current Time Service and Apple Notification Center Service (ANCS) available to an accessory. The Current Time Service supports the current time and local time information characteristics. The service does not provide an "Adjust Reason" when the current time changes. ANCS uses 7905F431-B5CE-4E99-A40F-4B1E122D00D0 as its UUID.

These services are not guaranteed to be available immediately after connection and the accessory must support Characteristic Value Indication of the Service Changed characteristic (see *Bluetooth 4.0* specification, Volume 3, Part G, Section 7.1) to be notified when the services become available. The Apple device will maintain a connection to an accessory as long as it is paired and uses one of the available services.

10.13 GATT Server

With iOS 6.0, applications may contribute services and characteristics to the GATT server that the Apple device makes available to the accessory. The recommendations in this section apply to the accessory in this case.

The following services are implemented internally by iOS and must not be published by third party iOS applications:

- Generic Attribute Profile Service
- Generic Access Profile Service
- Bluetooth Low Energy HID Service
- Battery Service
- Current Time Service
- Apple Notification Center Service

The Apple device implements the GAP Service Changed characteristic, because the database contents can change at any time. The accessory should therefore support the Characteristic Value Indication of this characteristic and, upon receiving indications, invalidate its database cache accordingly. See the *Bluetooth 4.0* specification, Volume 3, Part G, Section 7.1.

The accessory should minimize the use of ATT/GATT requests and commands and only send what is necessary. For example, do not use GATT Discover All Services when the accessory is looking for specific services. Use Discover Primary Service By Service UUID instead. Less airtime equals less power consumption and better performance for both the accessory and the Apple device.

When third party iOS applications discover services on the accessory, the following services are used internally by iOS and are filtered out from the list of discovered services:

- Generic Attribute Profile Service
- Generic Access Profile Service
- Bluetooth Low Energy HID Service
- Apple Notification Center Service

The accessory should be robust enough to handle any error gracefully. Pairing and Characteristic Value reads/writes may fail if the application that owns the service is not in the foreground and is not entitled to run in the background.

If an ATT Prepare Write Request is used, all queued attributes are contained within the same GATT Service.

11. Advanced Audio Distribution Profile (A2DP)

Accessories may implement the Advanced Audio Distribution Profile (A2DP) over Bluetooth (see [Bluetooth](#) (page 46)) to receive audio from Apple products.

The audio content from the Apple product can be broadly classified into two categories:

- Audio content from music, video, or gaming applications.
- System-generated sounds for alerts and notifications.

A2DP is often implemented in speakers and headsets.

Accessories that implement A2DP must satisfy all requirements stated in [Bluetooth](#) (page 46).

11.1 Bluetooth A2DP Specification

Every accessory that implements the Advanced Audio Distribution Profile must meet the requirements of the Bluetooth *Advanced Audio Distribution Profile* specification, Version 1.2.

11.1.1 AVDTP Transactions

Accessories must respond to Audio/Video Distribution Transport Protocol (AVDTP) signaling transactions before the Apple device's 5 second RTX_SIG_TIMER expires or the Apple device will terminate the signaling channel. See Section 6.2 "Transaction Model" and section 6.4 "Signal Command Set" of the Bluetooth *Audio/Video Distribution Transport Protocol*, Version 1.3.

11.2 SubBand Codec (SBC)

The SBC Codec Specific Information Elements, defined in Section 4.3.2 of the A2DP specification, that are applicable to Apple products are listed in [Table 11-1](#) (page 66).

Table 11-1 SubBand Codec Information Elements for Apple products

Element	Value
Sampling Frequency	44,100 Hz
Channel Mode	Stereo
Block Length	16

Element	Value
Subbands	8
Allocation Method	Loudness
Bitpool range	2 to 53. Accessories for Apple products should support 53.

11.3 MPEG 2/4 AAC Codecs

Apple devices support the non-mandatory codec MPEG-2/4 AAC, as defined in Section 4.5 of the *Advanced Audio Distribution Profile* specification, Version 1.2. Accessories should use the AAC codec in addition to SBC, because it provides higher audio quality for a given bit rate.

Note: The following specifications provide details of Apple's implementation of the MPEG-2/4 AAC codec. In case of conflicts, the A2DP specification governs.

The MPEG 2/4 AAC Codec Specific Information Elements, defined in Section 4.5 of the A2DP specification, that are applicable to Apple devices are listed in [Table 11-2](#) (page 67).

Table 11-2 MPEG-2/4 AAC Codec Information Elements for Apple devices

Element	Value
Object Type	MPEG-2 AAC LC
Sampling Frequency	44,100 Hz
Channels	2
Bit rate	264,630 bps
VBR	0

AAC audio stream packets in Apple devices have the structure shown in [Table 11-3](#) (page 67).

Table 11-3 AAC audio packet for Apple devices

L2CAP	AVDTP	MPEG-4 LATM	MPEG-4 AAC
Header	Header	AudioMuxElement	Audio Payload

The AAC Media Payload Format, as defined in Section 4.5.4 of the A2DP specification, is formatted using LATM, as defined in Section 4 of *IETF RFC 3016*. The following notes apply to the packet fields shown in [Table 11-3](#) (page 67).

- The recommended L2CAP MTU value for each Apple device's AAC streaming channel is 885 bytes.
- The AVDTP Header is shown as the RTP header in Figure 4 of RFC 3016, and is the header defined in Section 7.2.1 of the *Bluetooth Audio/Video Distribution Transport Protocol, Version 1.2*.

- The AudioMuxElement is the same as the RTP payload in RFC 3016. It is defined in Section 1.7.3, Table 1.41 in ISO/IEC 14496-3:2009, subpart 1. The muxConfigPresent argument to the AudioMuxElement is set to 1 (in-band mode), as recommended in Section 4.1 of RFC 3016. As recommended in Section 4.3 of RFC 3016, only one AudioMuxElement is put into each AVDTP packet.
- The audio payload is encoded using MPEG-4, as recommended in Section 4.5.4 of the A2DP specification.
- For AAC-LC support, the accessory should support VBR capability. The Apple device will be varying AAC bit rate depending on the content and the accessory should be able to handle the variation without causing gap in the audio.

11.4 Test Procedures

11.4.1 Audio Quality

Verify that there are no audio quality issues in each of the following scenarios:

1. Stream music from the Music app.
2. Stream music from a radio station within the Music app.
3. Stream audio using the Podcast app.

11.4.2 Audio Switching

1. During A2DP streaming, switch audio back to Apple device and switch back to accessory.
2. Audio should be routed to the intended source. Audio quality should be good switching back to Bluetooth.

11.4.3 HFP Interaction

1. Make incoming / outgoing call during A2DP.
2. Audio should be suspended during the call and resume after the call.

11.4.4 Siri

1. Trigger Siri during A2DP.
2. Audio should be resumed after the Siri session.

11.4.5 Video Playback

1. Stream A2DP while watching a video.
2. Audio / video synchronization and quality should be good.

12. Bluetooth Accessory Identification

This chapter describes Apple-specific Bluetooth commands that extend accessory capabilities beyond those supported by standard Bluetooth profiles.

To enable Apple-specific features, the accessory must support [HFP Command AT+XAPL](#) (page 69), which provides accurate information about the accessory's supported features. The Apple device will use the information sent by this command to enable and disable custom commands.

The accessory must send the following AT+XAPL command after making a successful HFP Service Level Connection (SLC) to the Apple device. The accessory should send an AT+XAPL command first, before sending any of the additional Apple-specific commands described below.

12.1 HFP Command AT+XAPL

Description: Enables custom AT commands from an accessory.

Initiator: Bluetooth accessory

Format: AT+XAPL=*vendorID-productID-version,features*

Parameters:

- *vendorID*: A string representation of the hex value of the vendor ID from the manufacturer, without the 0x prefix.
- *productID*: A string representation of the hex value of the product ID from the manufacturer, without the 0x prefix.
- *version*: The revision of the software.
- *features*: A base-10 representation of a bit field. Available features are:
 - Bit 0 = reserved
 - Bit 1 = The accessory supports battery reporting (reserved only for battery operated accessories).
 - Bit 2 = The accessory is docked or powered (reserved only for battery operated accessories).
 - Bit 3 = The accessory supports Siri status reporting.
 - Bit 4 = the accessory supports noise reduction (NR) status reporting.
 - All other values are reserved.

Example: AT+XAPL=ABCD-1234-0100,10 (Supports battery reporting and Siri status)

12. Bluetooth Accessory Identification

12.1 HFP Command AT+XAPL

Response: +XAPL=iPhone,*features*

13. Bluetooth Headset Battery Level Indication

Any Hands-Free Bluetooth headset accessory can show its battery level to the user as an indicator icon in the Apple device status bar. This feature is supported on all Apple devices that support the Hands-Free Profile, including iPhone, iPod touch, and iPad.

Headset battery indication is implemented by two Apple-specific Bluetooth HFP AT commands, [HFP Command AT+XAPL](#) (page 69) and [HFP Command AT+IPHONEACCEV](#) (page 71)

13.1 HFP Command AT+IPHONEACCEV

Description: Reports a headset state change.

Initiator: Headset accessory

Format: AT+IPHONEACCEV=*Number of key/value pairs*, *key1*, *val1*, *key2*, *val2*, . . .

Parameters:

- *Number of key/value pairs*: The number of parameters coming next.
- *key*: the type of change being reported:
 - 1 = Battery Level
 - 2 = Dock State
- *val*: the value of the change:
 - Battery Level: string value between '0' and '9'
 - Dock State: 0 = undocked, 1 = docked

Example: AT+IPHONEACCEV=1,1,3

14. Siri

Siri enables a user to have rich interactions with an Apple device by primarily using their voice.

Accessories supporting Siri must not use an icon that resembles the Siri microphone icon.

The rest of this chapter is applicable to accessories that support Siri over Bluetooth.

14.1 Enabling Custom Siri Commands

Every accessory that supports Siri over Bluetooth must support [HFP Command AT+XAPL](#) (page 69). The Apple device will use the information sent by this command to enable and disable custom commands related to Siri.

To receive Siri status events, the accessory must send the AT+XAPL command after making a successful HFP Service Level Connection (SLC) to the Apple device. The accessory should send an AT+XAPL command first, before sending any of the additional Siri-specific commands described below.

14.2 Obtaining Siri Availability Information

After establishing an HFP profile connection, an accessory can determine if Siri is available and enabled on an Apple device. It can also receive notifications of changes in Siri status. If Siri is disabled, Voice Control will be activated instead.

14.2.1 Obtaining Status Information at Connection

The accessory should send the following command after making a successful HFP profile (SLC) connection and sending an AT+XAPL command.

14.2.1.1 HFP Command AT+APLSIRI?

Description: AT command to retrieve Siri status information.

Initiator: accessory

Format: AT+APLSIRI?

Response: +APLSIRI: *value*

Defined Values:

- 0 = Siri is not available on this platform.
- 1 = Siri is available and enabled.
- 2 = Siri is available but not enabled.

Example: +APLSIRI : 1 (Siri is available and enabled)

14.2.2 Receiving Siri Availability Updates from the Apple Device

After initialization has been completed, the Apple device will send the accessory the following notification if there is a change in Siri status. This notification will be provided only if the accessory has requested Siri status (by sending AT+APLSIRI?) at least once after connection, and if the Apple device has reported that Siri is available and enabled.

14.2.2.1 HFP Command +APLSIRI

Description: Unsolicited event indicating a change in Siri status.

Initiator: Apple device

Format: +APLSIRI : *value*

Defined Values:

- 1 = Siri is available and enabled.
- 2 = Siri is available but not enabled.

Example: +APLSIRI : 2 (Siri is available but not enabled)

Figure 14-1 Siri is Disabled/Enabled from the Apple Device's Settings

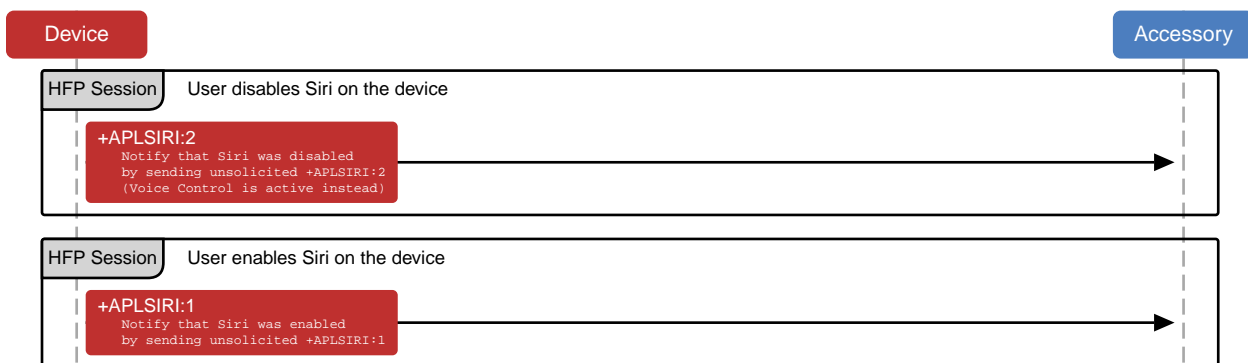

14.3 Initiating a Siri Session

Once support for Siri is established on both the accessory and the Apple device, a Siri session can be started from either one.

14.3.1 Initiating a Session from the Accessory

To initiate a Siri session, the accessory must use the voice recognition command AT+BVRA defined in the Bluetooth *Hands-Free Profile* specification. For further details, see the Bluetooth *Hands-Free Profile* 1.6 profile specification, section 4.25. The HFP profile must be connected and SLC must exist.

The accessory should use the following command sequence:

- The accessory sends an AT+BVRA=1 command to the Apple device.
- The Apple device sends an OK response.
- The Apple device launches a Siri session and creates a Synchronous Connection (SCO) for the audio.
- If the Siri session is not finished, the accessory must send AT+BVRA=1 to continue the conversation. This may need to happen multiple times.
- When the Siri session is finished, the Apple device sends a +BVRA:0 result code to the accessory.
- The Apple device disconnects the SCO connection.

While a Siri session is active, the accessory must let the user continue the conversation and ask follow up questions within the current context. In order to do so, the accessory must be able to send an AT+BVRA=1 command to the Apple device even after Siri has been already activated and before +BVRA:0 is received. [Figure 14-2](#) (page 74) shows an overview of the interaction when Siri is triggered from the accessory, the running session was continued twice and once Siri was finished, the device dismissed the session.

Figure 14-2 Initiating a Siri Session from the Accessory

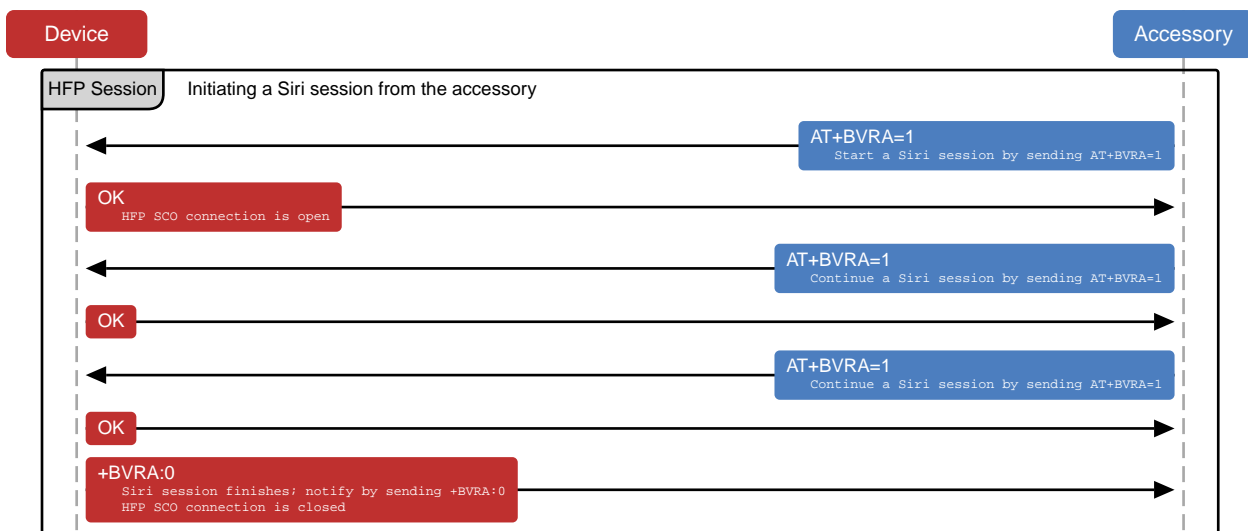

14.3.2 Initiating a Session from the Apple Device

If the accessory supports voice recognition commands, the Apple device sends a +BVRA event to indicate the start of a Siri session. The accessory must enable support for voice recognition and indicate it in its feature response as described in the Bluetooth *Hands-Free Profile 1.6* specification, section 4.34.1, "Bluetooth Defined AT Capabilities." Specifically, the HFP profile must be connected, SLC must exist, and voice recognition activation (bit 3) must be enabled in the AT+BRSF command. The Apple device will not use virtual call functionality for the Siri session if voice recognition activation is supported by the accessory.

The accessory should expect the following command sequence:

- The Apple device sends a +BVRA: 1 event to the accessory.
- The Apple device launches a Siri session and creates a SCO connection for the audio.
- When the Siri session is finished, the Apple device sends a +BVRA: 0 result code to the accessory.
- The Apple device disconnects the SCO connection.

Figure 14-3 Initiating a Siri Session from the Apple Device

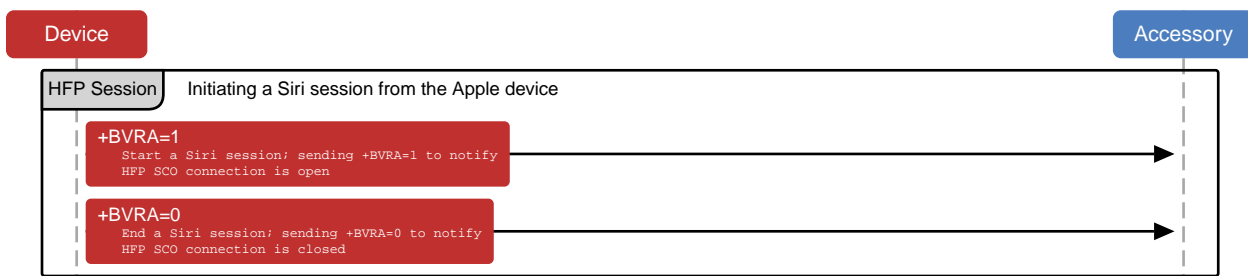

14.3.3 Ending a Session from the Accessory

Once a Siri session is running the accessory must be capable of ending the session by sending an AT+BVRA=0 command to the Apple device. Figure 14-4 (page 76) shows an example of ending a running Siri session from the accessory. The accessory should only end an active session as a result of a direct user action.

Figure 14-4 Ending a Siri Session from the Accessory

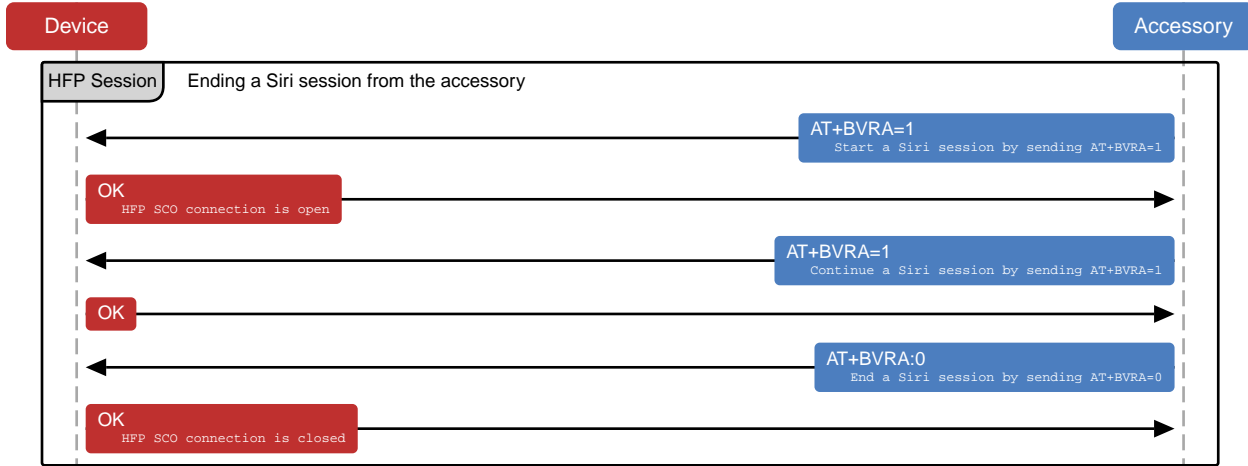

14.4 Siri Eyes Free Mode

Siri Eyes Free mode is a feature to control Siri responses that include display information and can be enabled or disabled as needed. In Eyes Free mode, the user experience is tailored towards a driving scenario and interactions with Siri are done primarily via voice to minimize the need for the user to look at a screen. Siri Eyes Free mode is supported only for Bluetooth-enabled vehicle entertainment systems and should not be used by any other accessories. Siri Eyes Free should not be triggered via a voice command.

The Apple device will listen for the HFP AT command `AT+APLEFM` to enable or disable Eyes Free mode.

This command is used by the Apple device to modify Siri responses that contain visual information or require user interaction. Suitable audio feedback and voice commands will be available to the user based on the Siri use case that was initiated.

Eyes Free mode is disabled by default. Once the accessory has enabled Eyes Free mode, it remains enabled for all subsequent Siri sessions initiated from the accessory until the accessory disables it or the Bluetooth connection is disconnected.

14.4.1 HFP Command `AT+APLEFM`

Description: An accessory sends this command to notify an Apple device of the preferred state of Eyes Free mode.

Initiator: accessory

Format: `AT+APLEFM=value`

Response: OK

Defined Values:

- 0x00 = Disable Eyes Free mode.
- 0x01 = Enable Eyes Free mode.
- 0x02-0xFF = reserved

Example: AT+APLEFM=1

14.5 Improving Voice Recognition

The microphone audio that the accessory sends to the Apple device during a Siri session should be suitable for voice recognition. Audio requirements for optimal voice recognition may differ from requirements for optimal human perception (such as during a cellular phone call).

Filtering of the audio signal to remove echoes or feedback noise is acceptable.

To provide the best possible audio quality as Siri input, the accessory must observe the following recommendations:

- **Echo cancellation and noise suppression (EC/NR):** Directional microphones and linear beamforming with microphone arrays giving improved SNR are recommended. Linear echo cancellation for reducing unwanted audio sources (such as audio output from the system) without having any other effect on the speech signal are also recommended. However, single channel noise reduction methods (such as spectrum subtraction) must not be applied, as they will be detrimental to the speech recognition accuracy. Similarly, automatic gain control, residual echo suppression and attempts to blank out non-speech periods in the waveform must not be applied.
- **Signal gain:** When adjusting signal levels, the accessory must avoid artifacts, dropouts, and clipping in all circumstances. Automatic Gain Control is not recommended. If the accessory adjusts signal gain, the gain should be held constant across each spoken utterance. The nominal level measured at the uplink output of the accessory should be A-weighted $-30 \text{ dB} \pm 2 \text{ dB}$ root-mean-square (RMS), expressed in units relative to full-scale (dBFS(A)). Alternatively, the nominal level may be $13 \text{ dB} \pm 2 \text{ dB}$ SLR if using the ITU measurement procedure.
- **Signal-to-noise ratio (SNR):** An average SNR greater than 20 dB is recommended. Below 20 dB, recognition rates will be impacted.
- **Reverberation:** Maintaining RT60 time at less than 200 ms is recommended.

14.5.1 Wide Band Speech Support

An accessory using Siri should support 16 kHz wide band speech audio for better audio quality and voice recognition performance. See the Bluetooth *Hands-Free Profile* 1.6 specification for details about wide band speech audio. Narrow band audio signal (8 kHz) is supported but not recommended.

14.6 Optimizing the Siri Experience

For best results in using Siri, the accessory design should follow these guidelines:

- The start of a Siri session should not be accompanied by local beeps or verbal indications (such as an announcement of "...voice dialing...") from the accessory. When a Siri session becomes active, the Apple device sends two beeps indicating that Siri is ready to receive instructions. Adding extra audible notifications only inserts delays in the system.
- The accessory should wait for the Apple device to end each Siri session. The accessory should not send an `AT+BVRA=0` command unless it is prompted to do so by user interaction.
- The Apple device expects that the accessory is capable of rendering audio as soon as the SCO connection is active. This is necessary to make sure that the user always hears the Siri introductory beeps with minimum delay. The delay should be within 200 ms.

14.7 Common Siri Applications

Siri can send messages, find points of interests, place phone calls, and much more. As Siri capabilities are constantly growing, additional use cases may become available after the initial integration. In Eyes Free mode, some of these use cases may not be accessible as the user experience is tailored towards a driving scenario.

14.7.1 Initialization Procedure After Connection is Established

[Figure 14-5](#) (page 79) outlines the sequence the accessory has to trigger to be able to use Siri on an Apple device. After establishing an HFP profile connection, the accessory must first enable the custom Siri commands by sending `AT+XAPL` and provide the features it supports. After a confirmation is received from the device, the accessory should determine Siri's availability with `AT+APLSIRI?`.

Vehicles with Bluetooth-enabled infotainment systems can also enable Siri Eyes Free Mode during initialization. This is detailed in [Figure 14-6](#) (page 79).

Figure 14-5 Siri Initialization Procedure

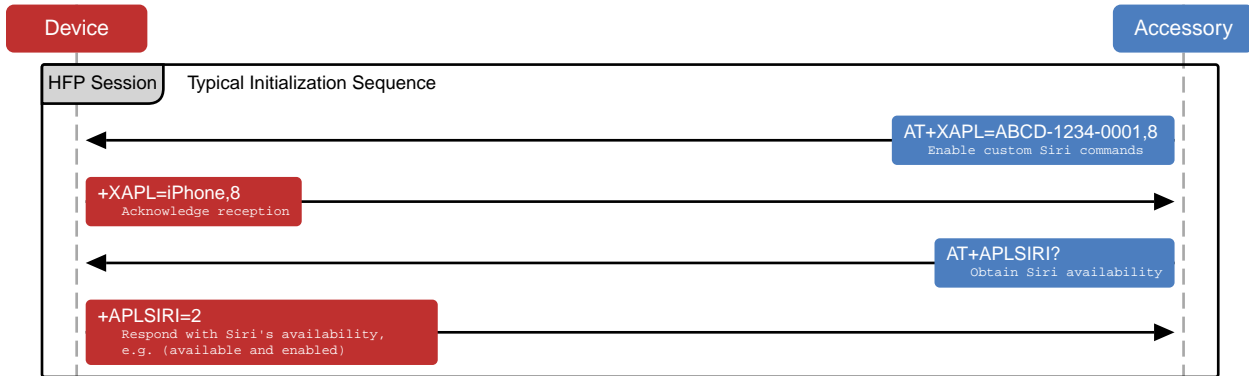
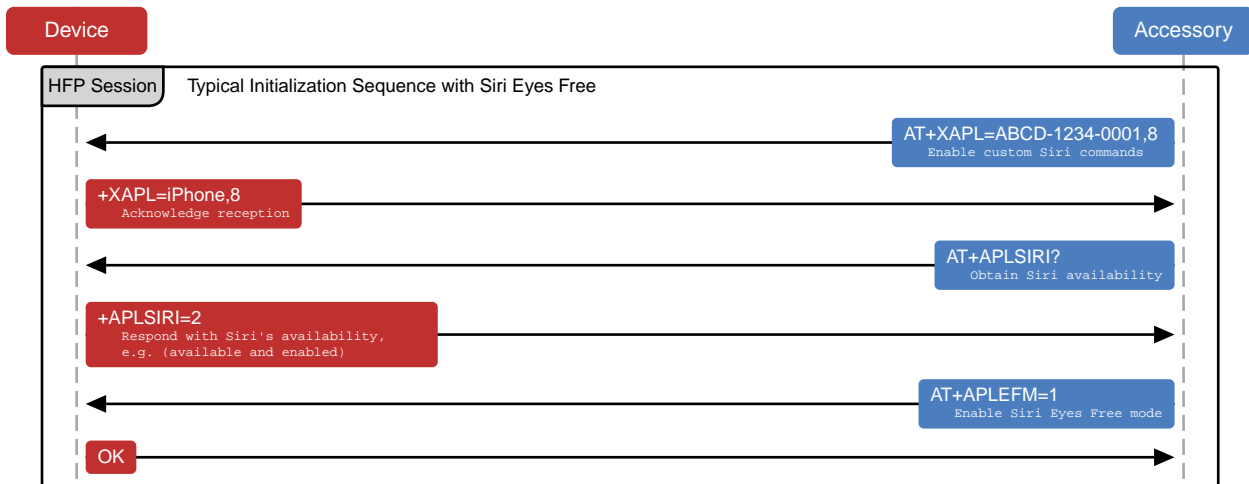

Figure 14-6 Siri Initialization Procedure with Siri Eyes Free



14.7.2 Phone Dialing Using Siri

Upon the user's request Siri can initiate an outgoing phone call. The Apple device will initiate HFP call signaling to establish a phone call as described in [Bluetooth](#) (page 46). The accessory must be able to transition to Hands-Free dialing at any time during or after a Siri session when signaled by the Apple device.

14.7.3 Audio Routing and Media Playback Using Siri

Siri can control the media playback on an Apple device, and if Siri determines that the user wants to play or pause music it will either start, pause or resume media playback. The Apple device will send a notification to the accessory indicating a change in playback state and any associated track information. The accessory must respond to those notifications, start or stop the music playback as requested, as well as update the correct playback state (e.g. shuffle, repeat).

The accessory must not force a change in the playback state after a Siri session is ended. If music was playing before Siri was started, it must continue playing, if it was paused, it must remain paused.

After Siri starts music playback the accessory must set its current audio route to match the audio source, depending on how audio is being received from the Apple device (via Bluetooth or by a wired connection).

The available media playback notifications depend on the audio route being used:

- For a Bluetooth audio route, use the approach described in [Notifications](#) (page 54) and [Audio Data Received via A2DP Profile](#) (page 56).
- For a wired audio route, use the iPod Accessory Protocol.

14.7.4 Turn-By-Turn Directions Using Siri

Siri can initiate active route guidance that will play turn-by-turn directions. In case the Apple device is the active source and is already playing music, turn-by-turn directions will be mixed in as part of the audio stream. In case the Apple device is not playing music, the accessory should be able to mix in turn-by-turn directions with the active audio source.

The Apple device will notify the accessory to play turn-by-turn directions only over Bluetooth. Detailed information on how to distinguish between music playback and turn-by-turn notifications is available in [Notifications](#) (page 54).

14.8 User Interaction with Siri Eyes Free in a Vehicle

A vehicle that uses Siri Eyes Free mode must integrate the Siri experience with the existing in-vehicle entertainment system and controls. The vehicle should provide a convenient interface to initiate, continue, and end a Siri session. Once a Siri session is running, the vehicle must display a visual cue that voice recognition is in process. [Figure 14-7](#) (page 81) outlines how a Siri interaction should be designed.

Figure 14-7 Siri Eyes Free User Interaction

Initiate or continue a Siri session

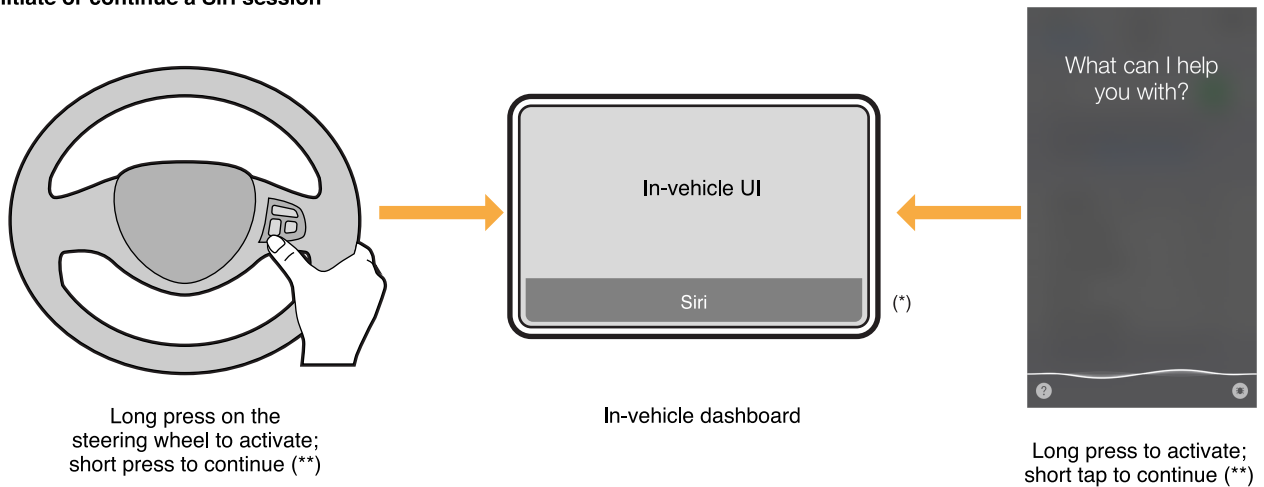

End a Siri session

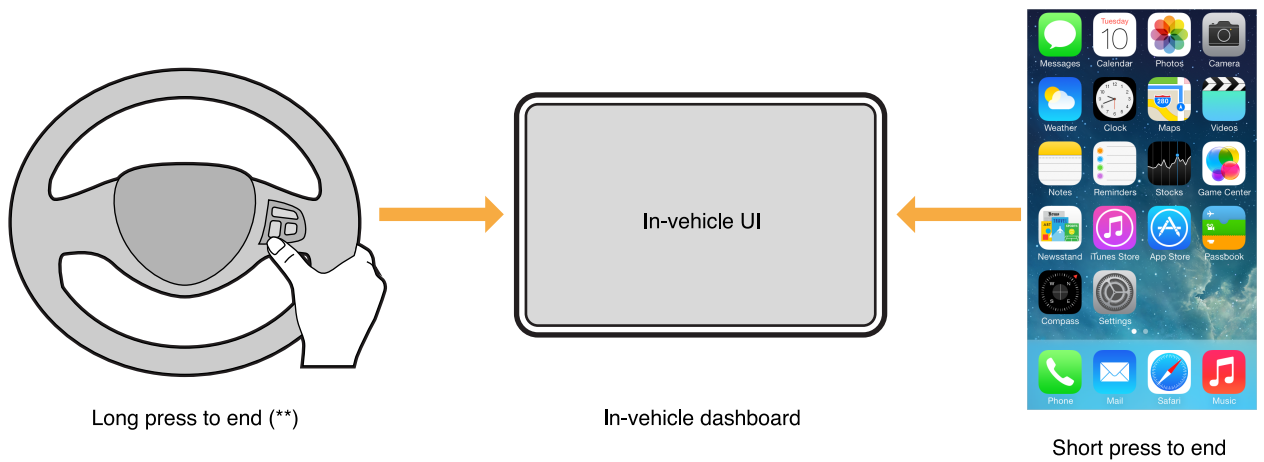

(*) If the accessory wishes to indicate that Siri is active, it must do one of the following:

- Display the word 'Siri'(as capitalized) with no additional text or icon.
- Use generic text or icon that does not resemble the Siri microphone icon.

(**) If the vehicle is equipped with steering wheel controls, a dedicated button or a long-press on a button on the vehicle's steering wheel is required to start, continue and end a Siri session. The button long-press must be 600 ms or less. If no steering wheel controls are available, a soft button must be available within the in-vehicle user interface to start, continue or end a Siri session.

When a vehicle enables Siri Eyes Free mode, the Apple device will not display any onscreen Siri content. If the device was locked at the time the Siri session was activated from the vehicle, it will remain locked and the screen will not turn on. If the user unlocks or manually activates the device while in an Eyes Free Session there will be a notification that the device is in an active Siri session but there will be no visual Siri content displayed.

14.9 Enabling/Disabling Siri from the Apple Device

The user has the ability to disable or enable Siri from the Settings menu on the Apple device. When Siri is disabled, Voice Control becomes the recognition engine on the device and will be triggered by default. The accessory may choose to either launch Voice Control with no further changes, in the same way Siri is launched (shown in [Figure 14-8](#) (page 82)) or display a warning message and not send an activation command to the Apple device ([Figure 14-9](#) (page 82)).

Figure 14-8 Siri is Deactivated - Launching Voice Control

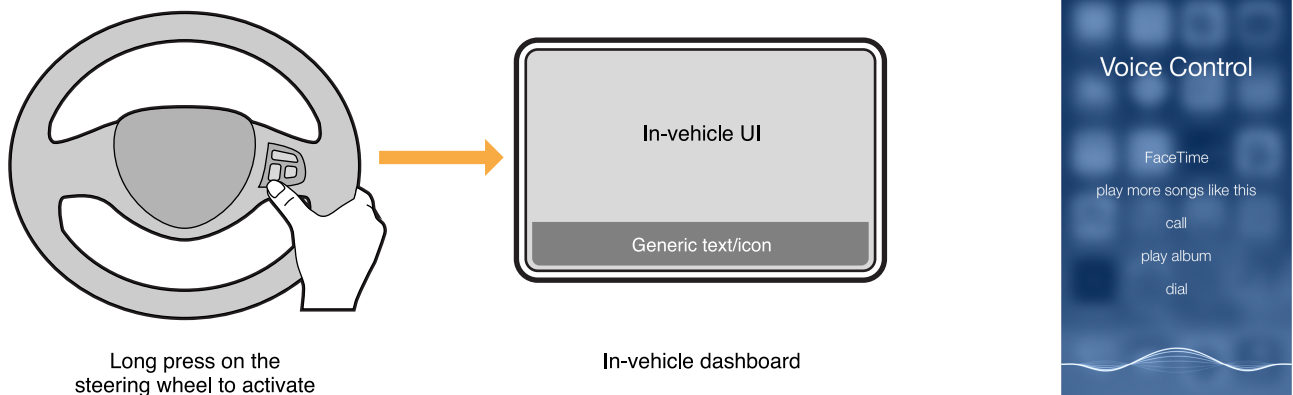
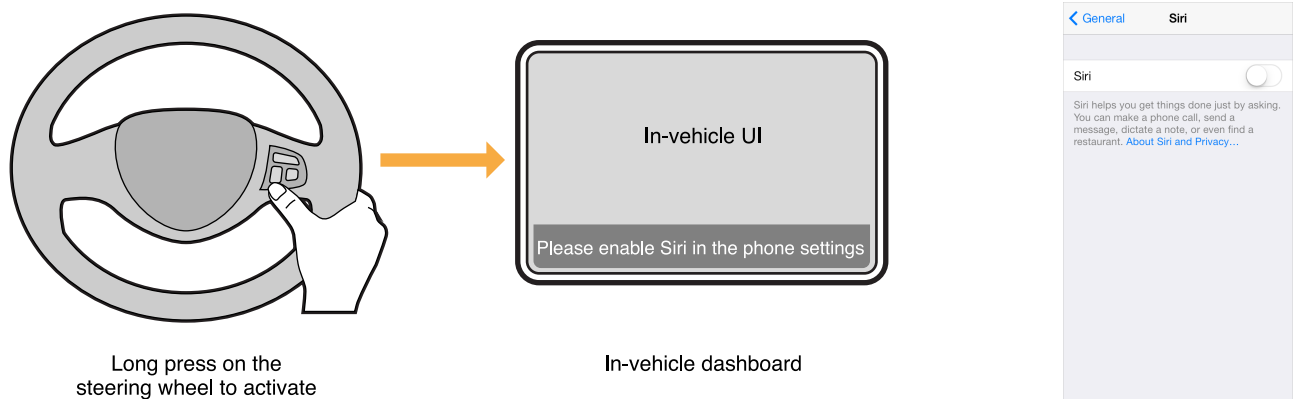

Figure 14-9 Siri is Deactivated - Displaying a Warning Message



14.10 Test Procedures

14.10.1 Siri Eyes Free

The following test procedures are applicable to accessories that interact with Siri Eyes Free.

For the following spoken tests, the speaker should ideally be a native speaker of North American English. If the tester's native language is not English, set Siri to your native language and translate the phrases to be spoken below into your native language.

14.10.1.1 General

1. Pair and establish a Bluetooth Handsfree Profile (HFP) connection between the iPhone and the head unit. Activate Siri from the vehicle steering wheel button (e.g. by press hold):
 - a. Observe that the iPhone screen remains inactive after a Siri session has started (a visual indicator will be visible on the Apple device if the screen is activated manually).
 - b. Ensure that Siri opening chime is heard completely through the vehicle speakers.
 - c. Observe a visual notification in the in-car User Interface (UI) that a Siri session is active (textual notification, on-screen UI, etc.).
2. Activate Siri from the vehicle steering wheel button and say "Send a message to Peter. How are you?". While still saying the message, press the vehicle steering wheel button to cancel Siri (e.g. by press):
 - a. Ensure the iPhone screen remains inactive (if manually activated, the visual indicator on the phone will disappear).
 - b. Verify that the in-car UI for Siri interaction dismisses and the head unit resumes the state before Siri's interaction.
3. Activate Siri from the vehicle steering wheel button and say "How is the weather in San Francisco?". Wait for Siri to respond with the weather forecast. Once the weather forecast is complete, resume Siri from the vehicle steering wheel button and say "What about New York?":
 - a. Observe that the visual indicator is still active on the phone.
 - b. Listen for the Siri opening chime.
 - c. The vehicle UI should be displaying an on-going Siri session.
 - d. Verify that Siri responds with the weather forecast for New York.
4. In case the vehicle UI offers on-screen controls to activate/cancel/resume Siri, repeat steps (1) to (3) for all on-screen controls.
5. Activate Siri from the steering wheel button and say "What's the time". Listen to the current time and do not interact with Siri or the iPhone. After 5 seconds have expired:
 - a. Observe that the visual indicator on the phone is no longer visible.
 - b. The in-car UI for Siri interaction should be dismissed.
 - c. The head unit should resume the state before Siri's interaction.
6. Listen to FM radio from the car speakers (no A2DP streaming active). Press and hold phone's Home button to activate Siri from the phone:

- a. Observe a visual notification in the in-car UI that a Siri session is active (textual notification, on-screen UI, etc.).
 - b. Observe Siri's interaction on the phone's screen and ask "What's the time?"
 - c. After Siri has responded, lock the phone again to dismiss the Siri session by pressing the phone's sleep/wake or side button.
7. On the phone go to Settings and turn off Siri. Activate Siri from the head unit. Observe one of the following depending on the actual implementation (a) Voice Control starts instead of Siri (b) The head unit displays a warning that Siri Eyes Free is not available.
 8. On the phone go to Settings and turn Siri back on. Verify that Siri can be activated/cancelled from the head unit and from the Home button on the phone.
 9. Turn Bluetooth off from the Settings on the phone. Verify that Siri cannot be started.
 10. Turn Bluetooth back on from the Settings on the phone. Verify that Bluetooth HFP profile reconnects and that Siri can be activated/cancelled from the head unit and from the Home button on the phone.
 11. Make sure there is no accessory battery status level indicator icon displayed on the phone's status bar.

14.10.1.2 Siri Dialog

1. Activate Siri from the vehicle's steering wheel button and say "Send a text message to **insert contact name**". When Siri prompts for "what would you like it to say", dictate a short message. After Siri has read back your dictated message, say "Review it". After Siri has read back the message again, say "Review it" again. Repeat this cycle ~5 times to ensure that the head unit is able to handle a long interaction with Siri. At the end say "Send it" and verify that the message is sent. Verify that the opening chime is audible and the message is sent. After the Siri session is closed, the audio playback should go back to the state it was before Siri was started, i.e. if it was paused remains paused, if it was playing remains playing.
2. Start Siri from the vehicle's steering wheel button and ask for directions. Follow up through the dialog until the navigation is started. Verify that the Siri session is closed and that the audio playback goes back to the state it was before Siri was started, e.g. if it was paused remains paused, if it was playing remains playing.
3. Start Siri from the vehicle's steering wheel button and say "Search the web for polar bears". Verify that Eyes Free mode is on and that this use case is blocked by Siri. Note: In some implementations the vehicle has to be in motion before Eyes Free is activated by the car kit.
4. Start Siri from the vehicle's steering wheel button and say "What is the current time in Munich?". After Siri has answered but before ~5 seconds have elapsed, resume Siri (e.g. by a short press on the steering wheel button) and verify that Siri is initiated again. Say "What about San Francisco?". Repeat (with a different city) and verify that this can continue indefinitely as long as you short press on the steering wheel button within 5 seconds of the last response.

14.10.1.3 Bluetooth HFP A2DP Music

1. Establish a Bluetooth A2DP connection and switch to Bluetooth audio source on the head unit. Activate Siri and ask "Next track". Verify that track advances and that audio is playing through vehicle speakers. Verify that the Siri in-car UI is dismissed and the head unit goes back to its initial state.
2. Activate Siri and say "Pause the music". Verify that audio remains paused after Siri has been dismissed. Verify that the Siri in-car UI is dismissed and the head unit goes back to its initial state.
3. Pause music playback on the head unit (via AVRCP command). Activate Siri and ask "What time is it?". Verify that the music playback remains paused after the Siri session has been dismissed. Verify that the Siri in-car UI is dismissed and the head unit goes back to its initial state.
4. Switch to FM radio on the head unit. Activate Siri and ask "Play me a song". Verify that head unit is able to automatically switch to BT audio and iPhone music starts playing. Verify that the beginning of the selected track is heard, e.g. there is no skipping of audio packets. Verify that the Siri in-car UI is dismissed and the head unit goes back to its initial state.
5. Activate Siri and ask "Shuffle all songs". Verify that head unit correctly updates NowPlaying track information. Verify that the Siri in-car UI is dismissed and the head unit goes back to its initial state.
6. Activate Siri and ask to play a specific artist or title. Verify that the Siri session is dismissed after the music starts. Make sure the correct metadata is displayed on the screen. Verify that the Siri in-car UI is dismissed and the head unit goes back to its initial state.

14.10.1.4 Call

1. Activate Siri and call a contact with more than one phone number (home and mobile). Wait for Siri's response to ask for which phone number to call. Answer with "home". Verify that call transition is handled correctly by the head unit and any Siri UI displayed on the vehicle screen is dismissed.
2. While iPhone music is playing, activate Siri and say "Call **insert contact name to call**". Verify that call transition is handled correctly by the head unit. Verify that iPhone music playback resumes after the call has been answered and terminated on the far end. Verify that the Siri in-car UI is dismissed and the head unit goes back to its initial state.
3. While iPhone music is playing, start Siri and say "Call **insert contact name to call**". Verify that call transition is handled correctly by the head unit. Verify that iPhone music playback resumes after the call has been answered and terminated on the near end (i.e. on the head unit). Verify that the Siri in-car UI is dismissed and the head unit goes back to its initial state.
4. While in a Siri session, receive an incoming call on the head unit. Verify that head unit handles call-signaling correctly and transitions to phone UI once the call has been accepted. Verify that the Siri in-car UI is dismissed and the head unit goes back to its initial state.

14.10.1.5 Bluetooth + Wired iAP

1. Connect Apple device to head unit via a Lightning connector (iPhone 5). Switch to iPod music and verify that audio is playing. Activate Siri and say "Next track". Verify that track advances and head unit displays track metadata correctly. Verify that the Siri in-car UI is dismissed and the head unit goes back to its initial state.
2. From the head unit UI, select a playlist with a single song and start playing it. Start Siri from the vehicle steering wheel and say "Play **make sure to select a song to play that is (a) not in the same album as the single-track playlist and (b) not song track index 0 of its album**". Verify that the new song starts playing and that the head unit displays the track metadata for this new song correctly. Verify that the Siri in-car UI is dismissed and the head unit goes back to its initial state.
3. Turn Shuffle off on the head unit UI. Then start Siri and say "Shuffle all songs". Verify that the shuffle indicator on the head unit UI is updated and the correct track metadata for the new now playing song is displayed correctly. Verify that the Siri in-car UI is dismissed and the head unit goes back to its initial state.
4. Switch to FM radio on the head unit. Activate Siri and say "Play me a song". Verify that head unit is able to automatically switch to iPod audio source and that audio starts playing through the speakers. Verify that there is no skipping of audio at the beginning of the selected track. Verify that the Siri in-car UI is dismissed and the head unit goes back to its initial state.
5. Pause music playback on the head unit (via iAP commands). Activate Siri and ask "What time is it?". Verify that music playback remains paused after Siri session has been dismissed. Verify that the Siri in-car UI is dismissed and the head unit goes back to its initial state.
6. While iPhone music is playing, start Siri and say "Call **insert contact name to call**". Verify that call transition is handled correctly by the head unit. Verify that iPhone music playback resumes after the call has been answered and terminated on the far end. Verify that the Siri in-car UI is dismissed and the head unit goes back to its initial state.
7. While iPhone music is playing, start Siri and say "Call **insert contact name to call**". Verify that call transition is handled correctly by the head unit. Verify that iPhone music playback resumes after the call has been answered and terminated on the near end (i.e. on the head unit). Verify that the Siri in-car UI is dismissed and the head unit goes back to its initial state.
8. Pause music playback on the head unit (via iAP commands). Start Siri and say "Call **insert contact name to call**". Verify that call transition is handled correctly by the head unit. Verify that iPhone music playback remains paused after the call has been answered and terminated on the far end. Verify that the Siri in-car UI is dismissed and the head unit goes back to its initial state.

15. iPod Accessory Protocol

Third-party accessories can use the iPod Accessory Protocol (iAP) to access advanced features of Apple devices. One such feature is the ability to communicate securely with third-party iOS applications via the iOS External Accessory Framework. For information about the External Accessory Framework, see <http://developer.apple.com/library/ios/#featuredarticles/ExternalAccessoryPT/Introduction/Introduction.html>.

To incorporate iAP into an accessory design, the accessory developer must be a member of the Apple MFi licensing program and integrate specific MFi hardware into the accessory. For further information about MFi, see <https://developer.apple.com/programs/mfi>.

References

16. Device Dimensional Drawings

This chapter contains the following dimensional drawings:

- [iPhone X](#) (page 91)
- [iPhone 8 Plus](#) (page 92)
- [iPhone 8](#) (page 93)
- [iPhone 7 Plus](#) (page 94)
- [iPhone 7](#) (page 95)
- [iPhone 6s Plus](#) (page 96)
- [iPhone 6s](#) (page 97)
- [iPhone 6 Plus](#) (page 98)
- [iPhone 6](#) (page 99)
- [iPhone 5s & iPhone SE](#) (page 100)
- [iPhone 5c](#) (page 101)
- [iPhone 5](#) (page 102)
- [iPad Pro \(10.5-inch\) with Wi-Fi](#) (page 103)
- [iPad Pro \(10.5-inch\) with Wi-Fi + Cellular](#) (page 104)
- [iPad Pro \(10.5-inch\) Magnet/Hall Effect Sensors](#) (page 105)
- [iPad Pro \(12.9-inch\) 2nd Generation with Wi-Fi](#) (page 107)
- [iPad Pro \(12.9-inch\) 2nd Generation with Wi-Fi + Cellular](#) (page 108)
- [iPad Pro \(12.9-inch\) 2nd Generation Magnet/Hall Effect Sensors](#) (page 109)
- [iPad \(5th and 6th generation\) with Wi-Fi + Cellular](#) (page 111)
- [iPad \(5th and 6th generation\) Magnet/Hall Effect Sensors](#) (page 112)
- [iPad Pro \(9.7-inch\) with Wi-Fi](#) (page 114)
- [iPad Pro \(9.7-inch\) with Wi-Fi + Cellular](#) (page 115)
- [iPad Pro \(9.7-inch\) Magnet/Hall Effect Sensors](#) (page 116)
- [iPad Pro \(12.9-inch\) 1st Generation with Wi-Fi](#) (page 118)
- [iPad Pro \(12.9-inch\) 1st Generation with Wi-Fi + Cellular](#) (page 119)
- [iPad Pro \(12.9-inch\) 1st Generation Magnet/Hall Effect Sensors](#) (page 120)
- [iPad mini 4 with Wi-Fi](#) (page 122)
- [iPad mini 4 with Wi-Fi + Cellular](#) (page 123)
- [iPad mini 4 Magnet/Hall Effect Sensors](#) (page 124)
- [iPad Air 2 with Wi-Fi](#) (page 125)
- [iPad Air 2 with Wi-Fi + Cellular](#) (page 126)
- [iPad mini 2 & iPad mini 3 with Wi-Fi](#) (page 127)

- [iPad mini 2 & iPad mini 3 with Wi-Fi + Cellular](#) (page 128)
- [iPad Air with Wi-Fi](#) (page 129)
- [iPad Air with Wi-Fi + Cellular](#) (page 130)
- [iPad mini with Wi-Fi](#) (page 131)
- [iPad mini with Wi-Fi + Cellular](#) (page 132)
- [iPad \(4th generation\) with Wi-Fi](#) (page 133)
- [iPad \(4th generation\) with Wi-Fi + Cellular](#) (page 134)
- [iPod touch \(6th generation\)](#) (page 135)
- [iPod touch \(5th generation\)](#) (page 136)

16.3 iPhone 8

Figure 16-3 iPhone 8 Dimensional Drawing

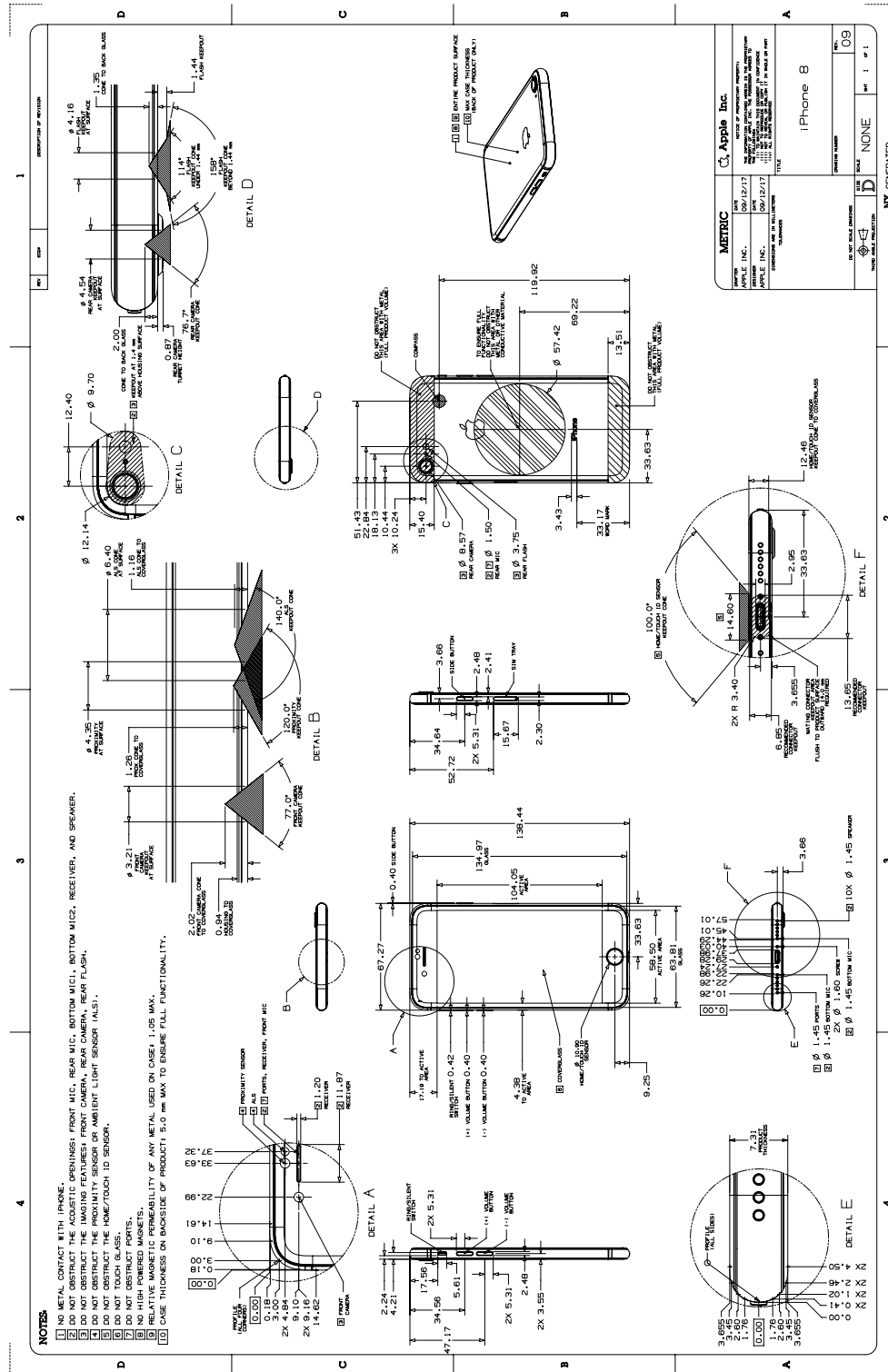

16.5 iPhone 7

Figure 16-5 iPhone 7 Dimensional Drawing

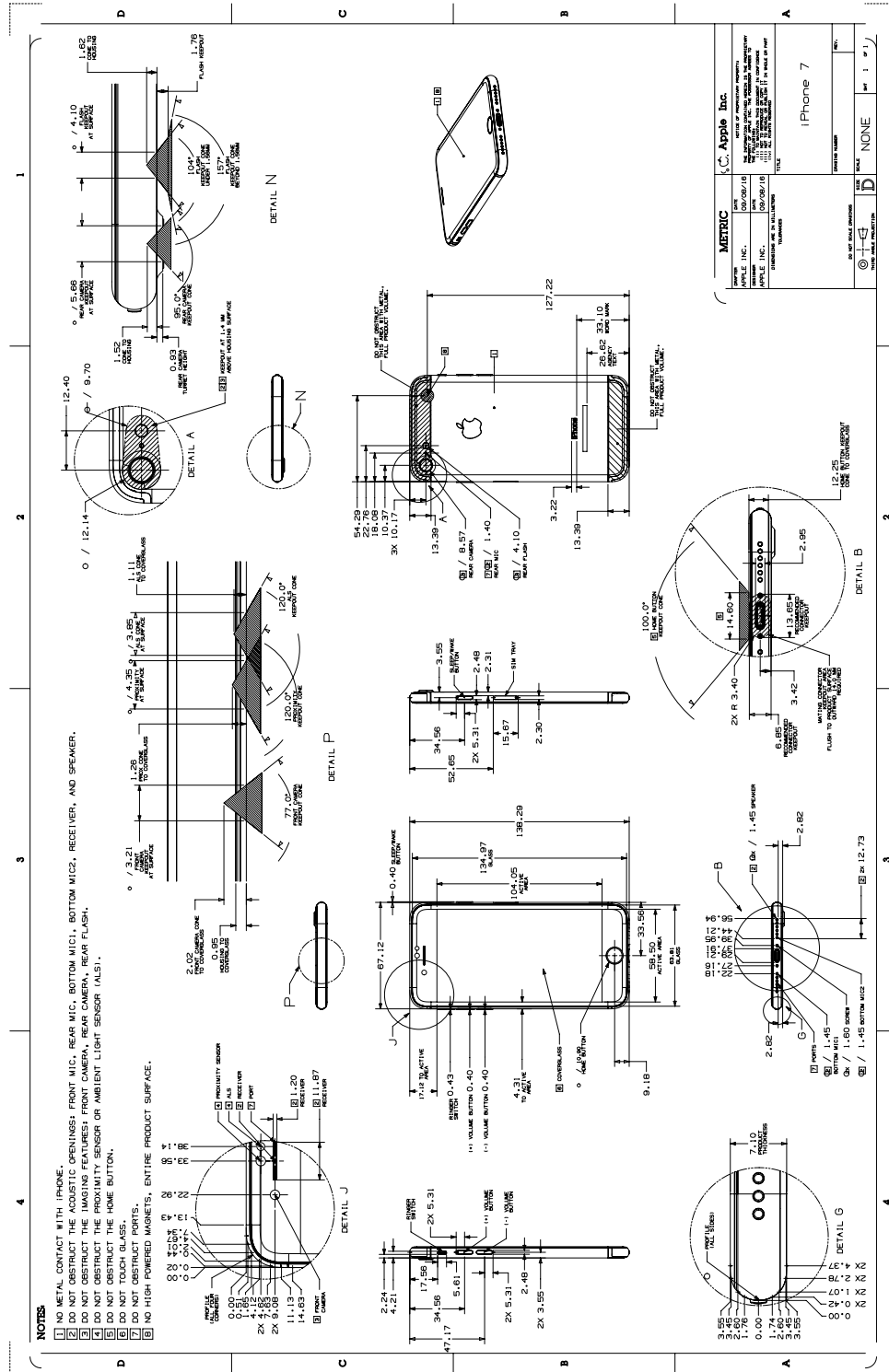

16.14 iPad Pro (10.5-inch) with Wi-Fi + Cellular

Figure iPad Pro (10.5-inch) with Wi-Fi + Cellular Dimensional Drawing
 16-14

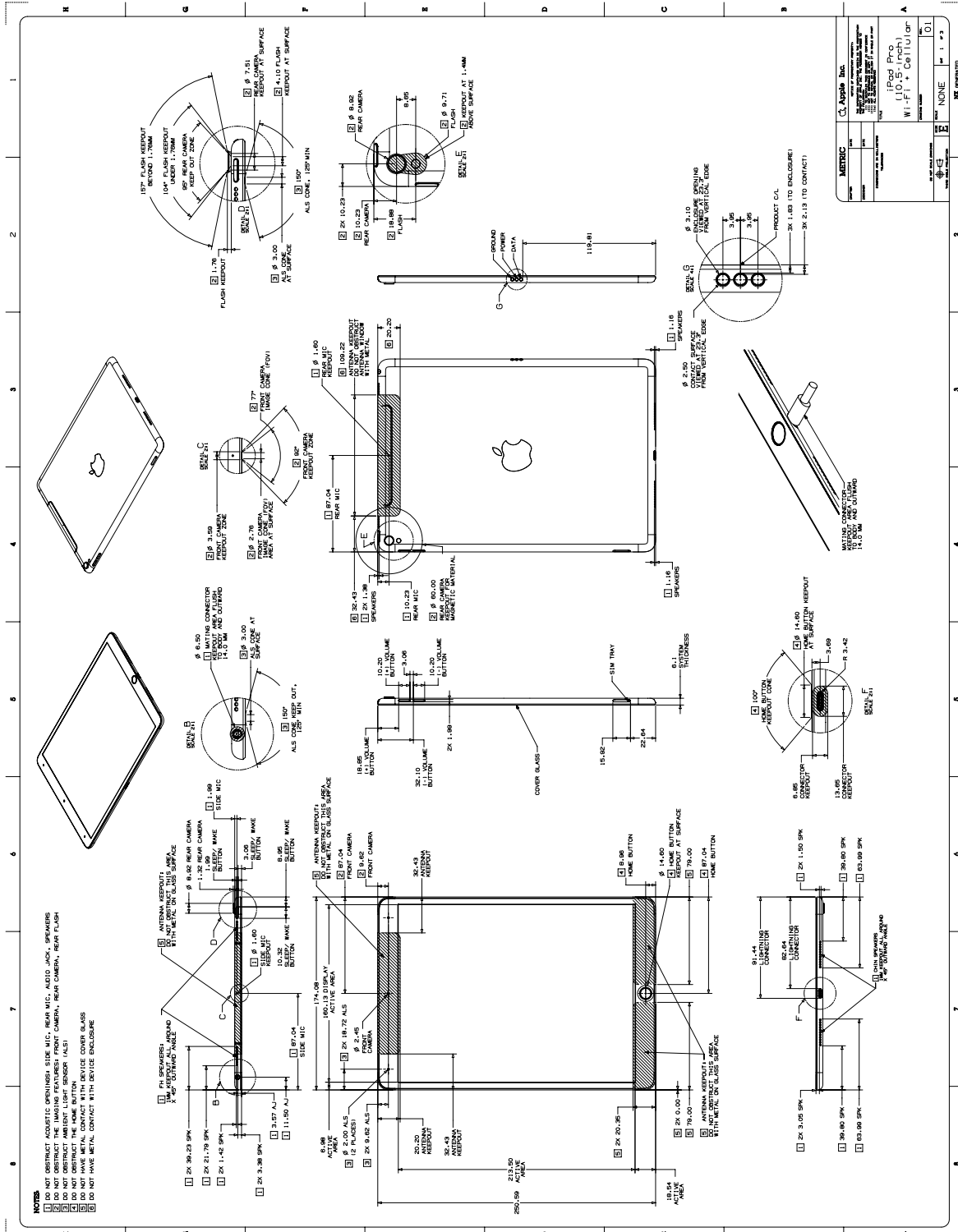
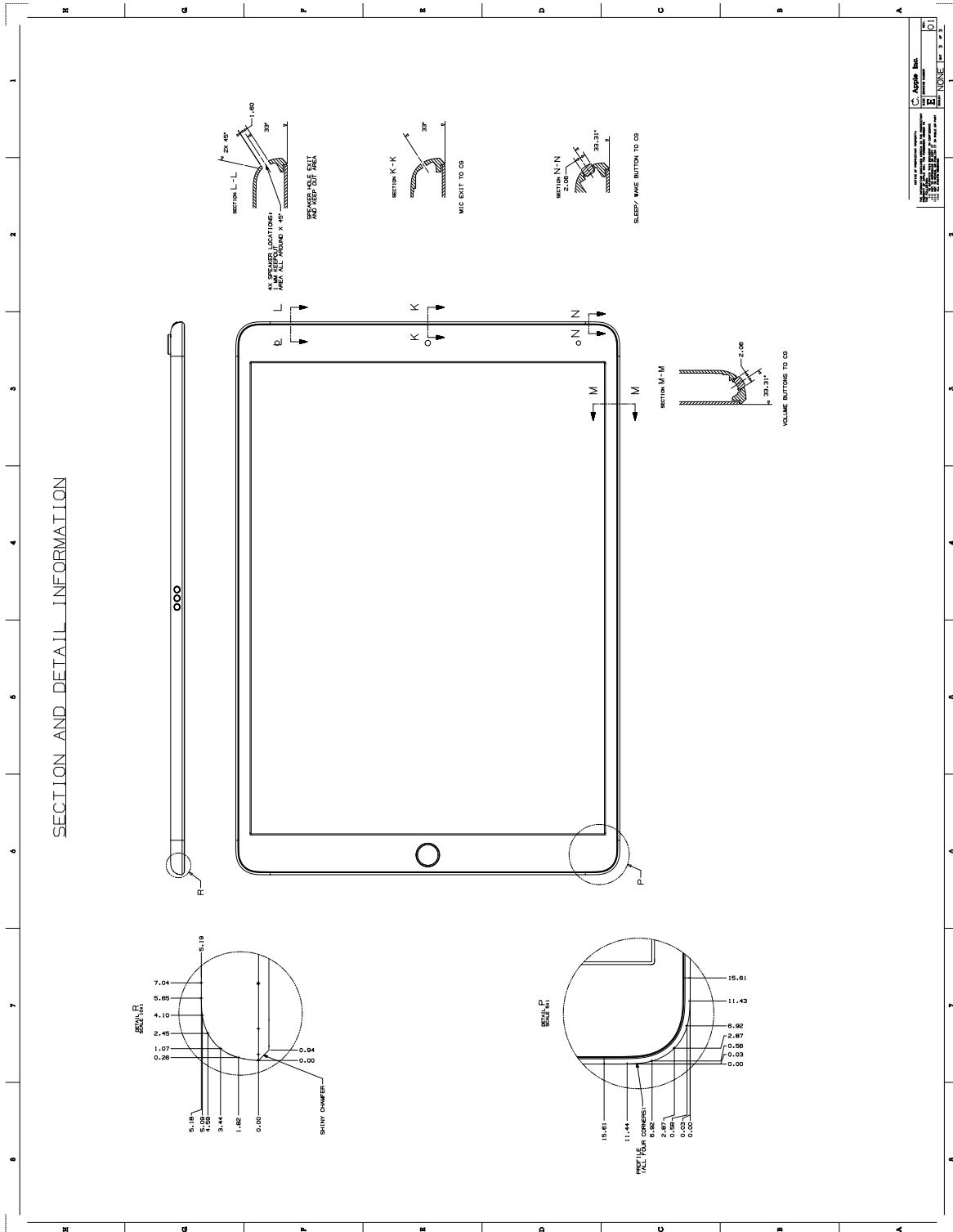
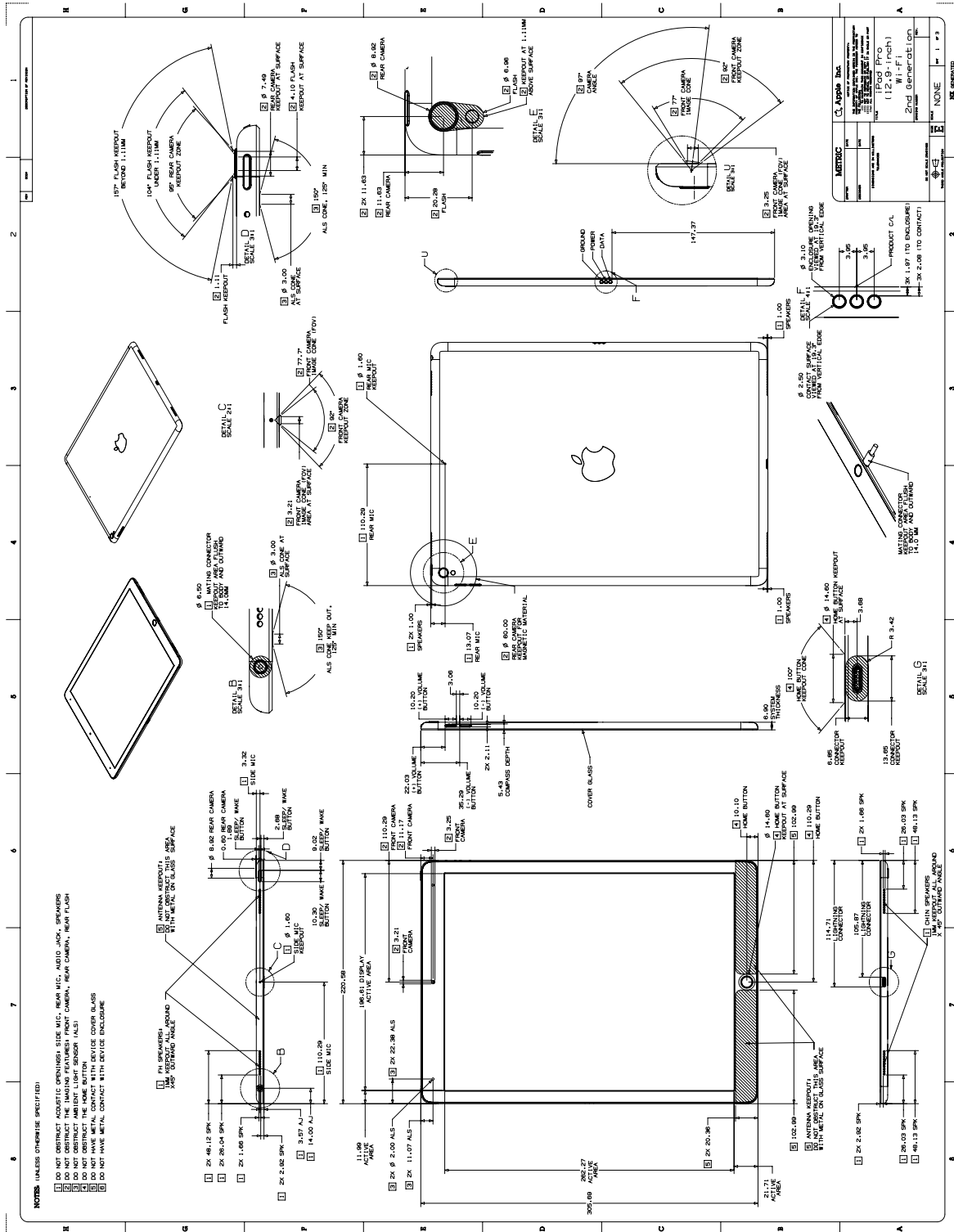

Figure 16-16 iPad Pro (10.5-inch) Magnet/Hall Effect Sensors 2 of 2 Dimensional Drawing



16.16 iPad Pro (12.9-inch) 2nd Generation with Wi-Fi

Figure 16-17 iPad Pro (12.9-inch) 2nd Generation with Wi-Fi Dimensional Drawing



16.19 iPad (5th and 6th generation) with Wi-Fi + Cellular

Figure 16-21 iPad (5th and 6th generation) with Wi-Fi + Cellular Dimensional Drawing

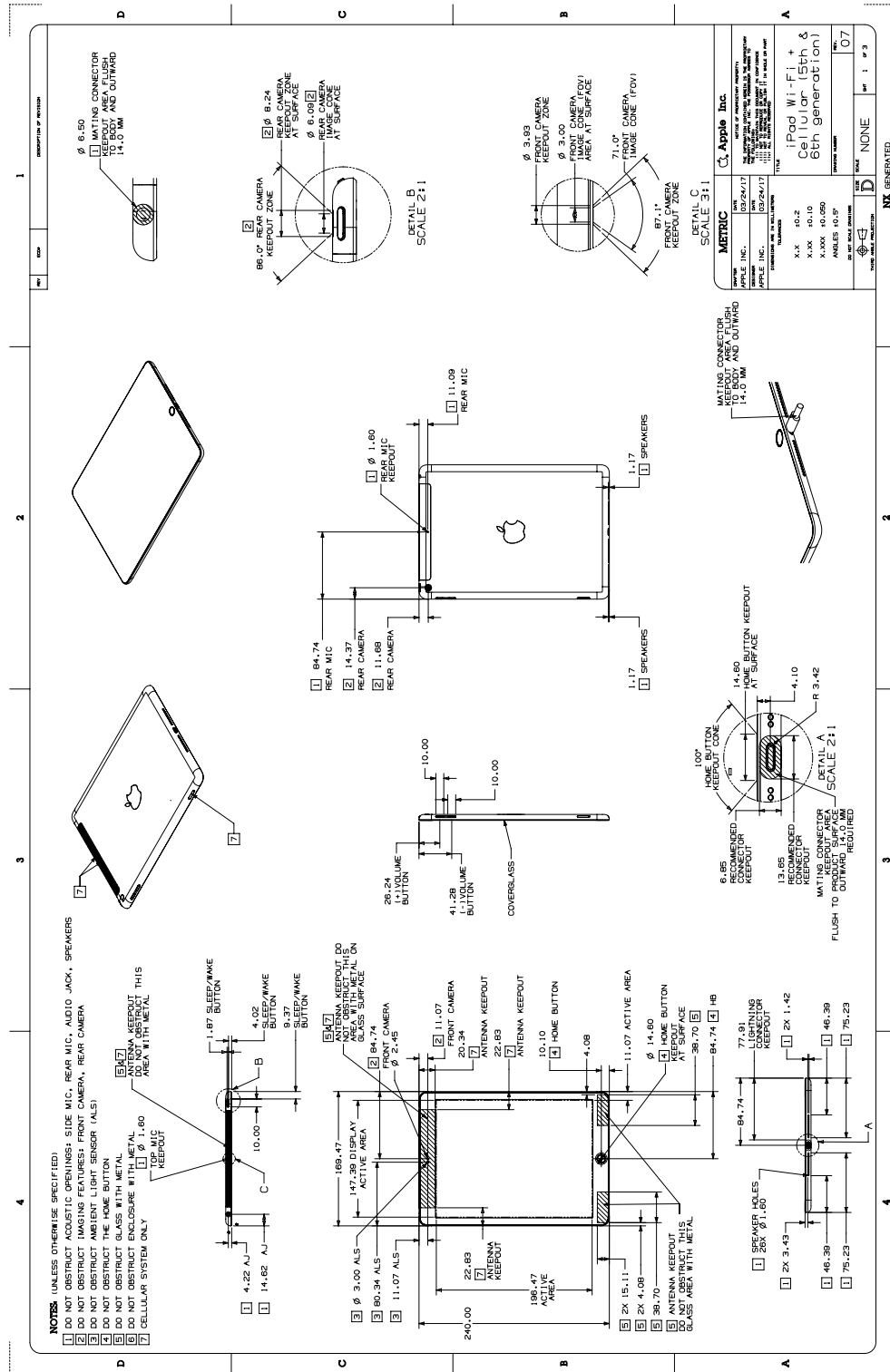
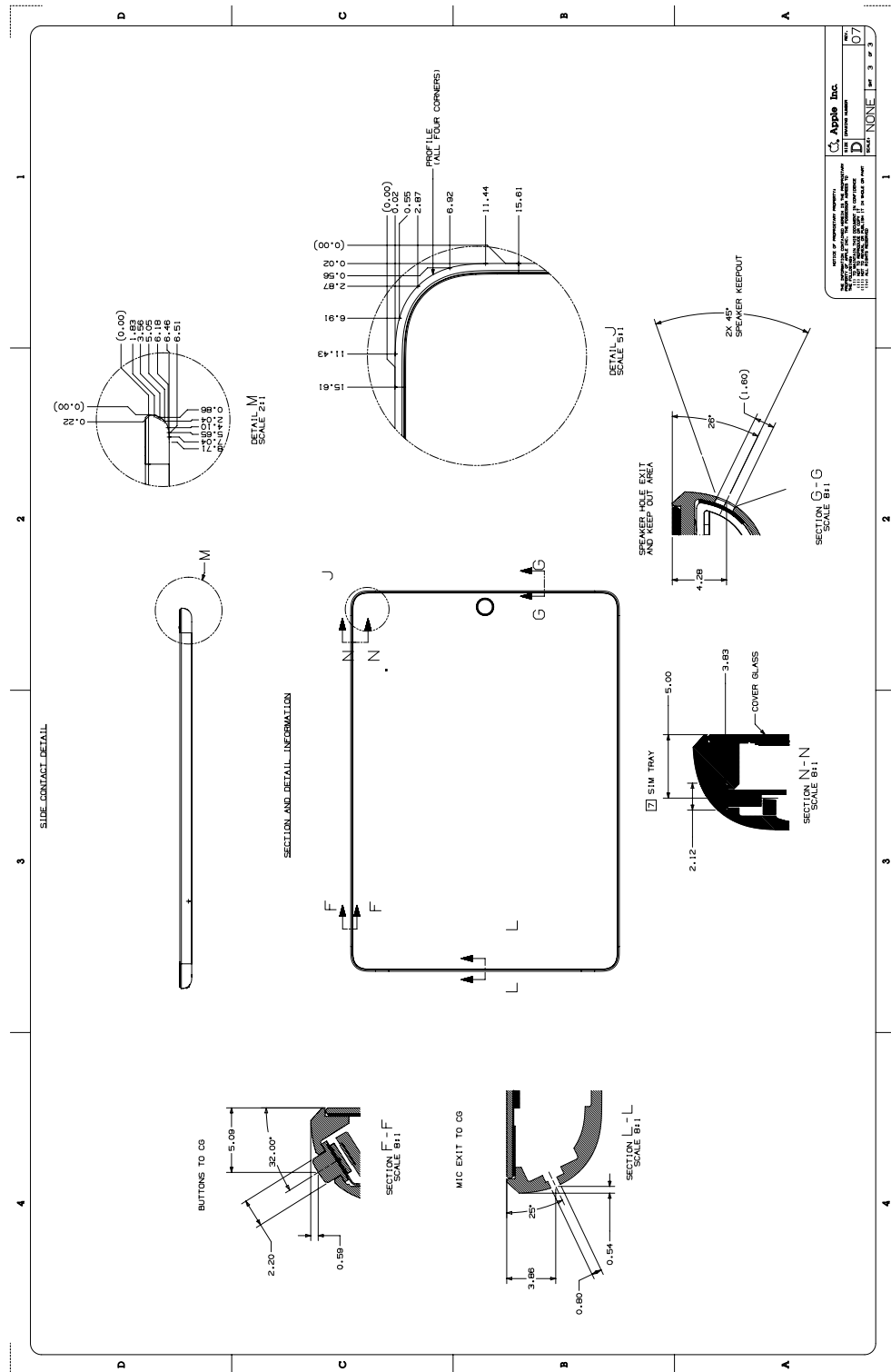
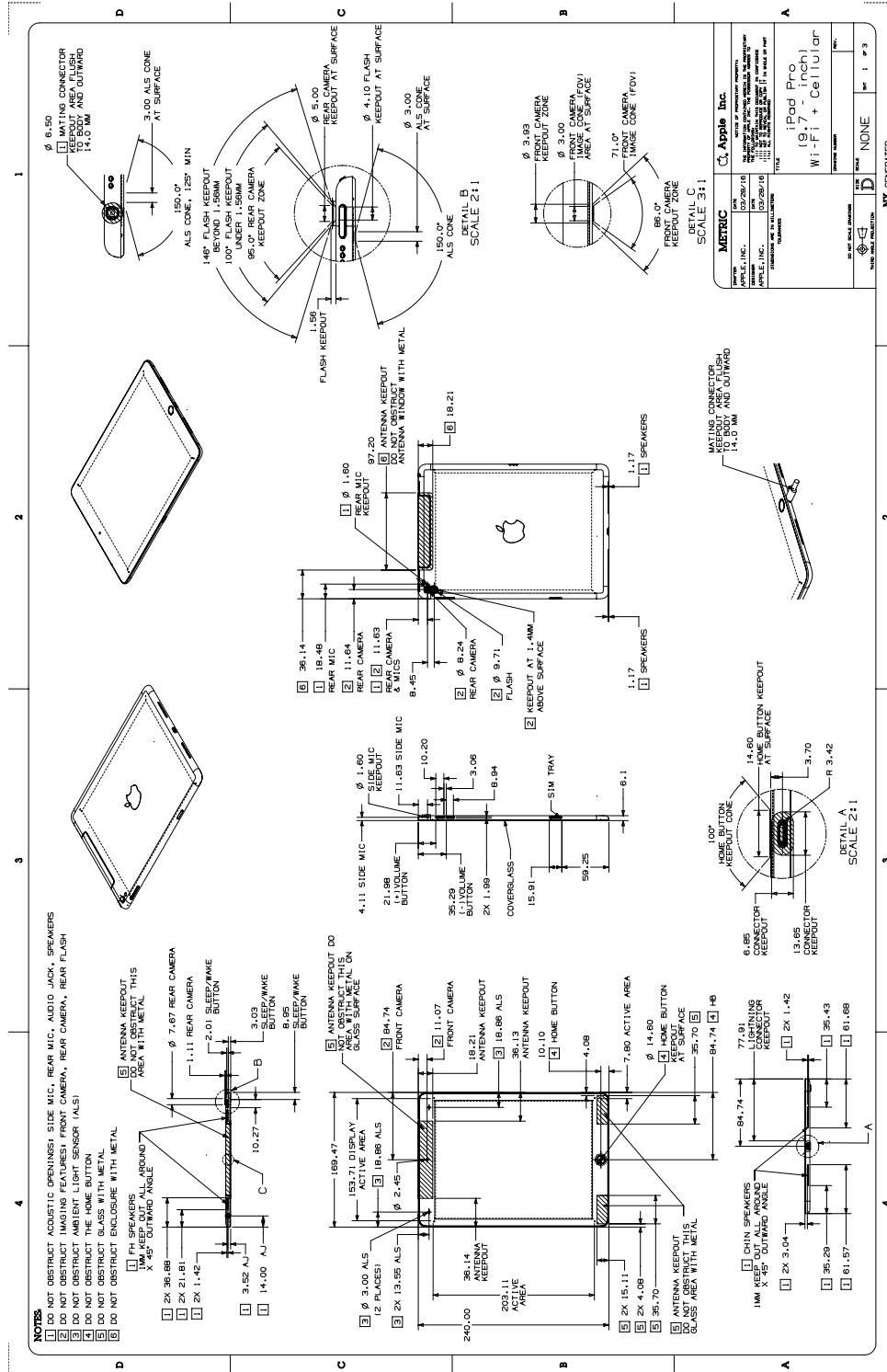

Figure iPad (5th and 6th generation) Magnet/Hall Effect Sensors 2 of 2 Dimensional Drawing
 16-23



16.22 iPad Pro (9.7-inch) with Wi-Fi + Cellular

Figure 16-25 iPad Pro (9.7-inch) with Wi-Fi + Cellular Dimensional Drawing



16.23 iPad Pro (9.7-inch) Magnet/Hall Effect Sensors

Figure 16-26 iPad Pro (9.7-inch) Magnet/Hall Effect Sensors 1 of 2 Dimensional Drawing

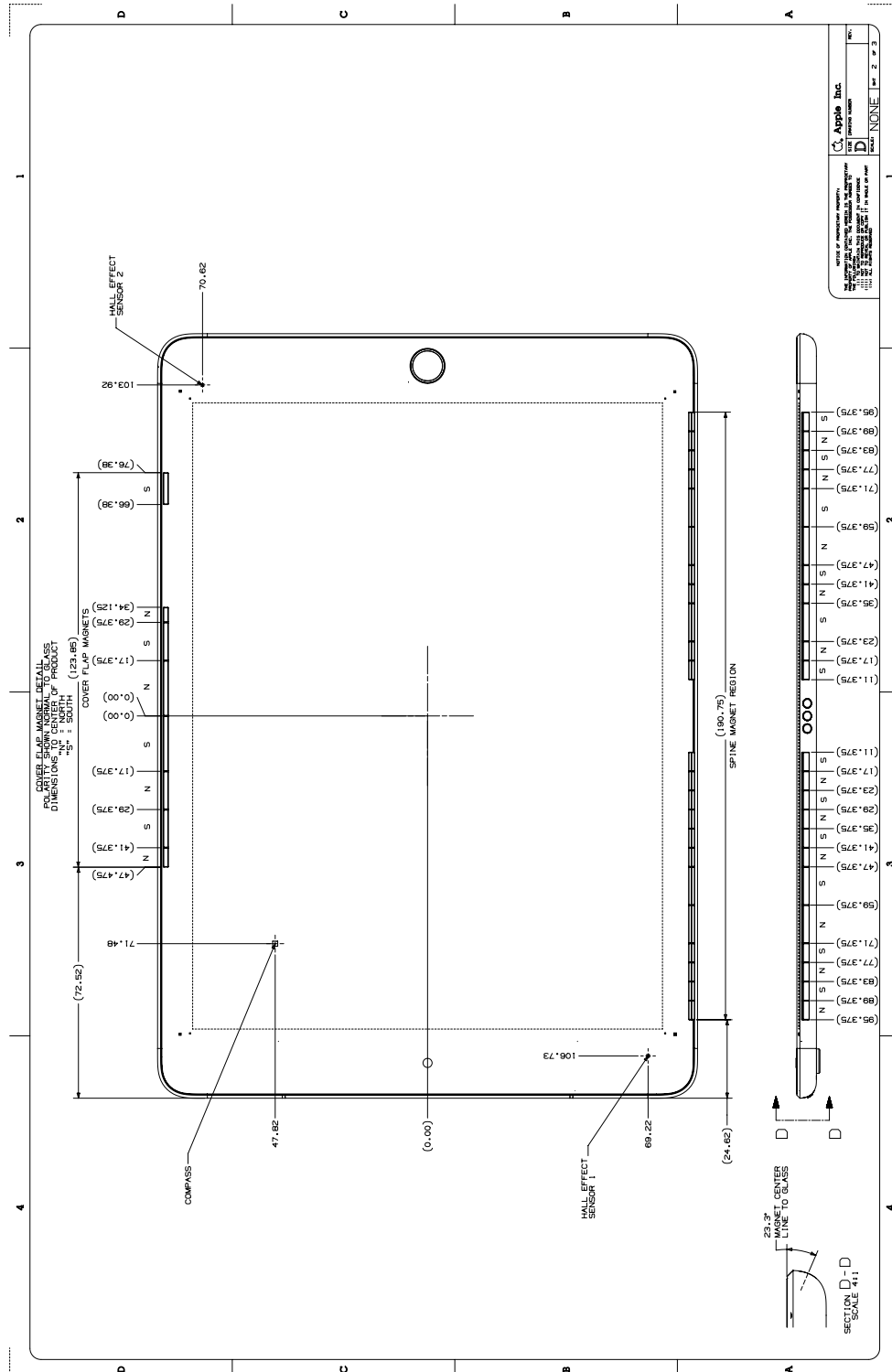
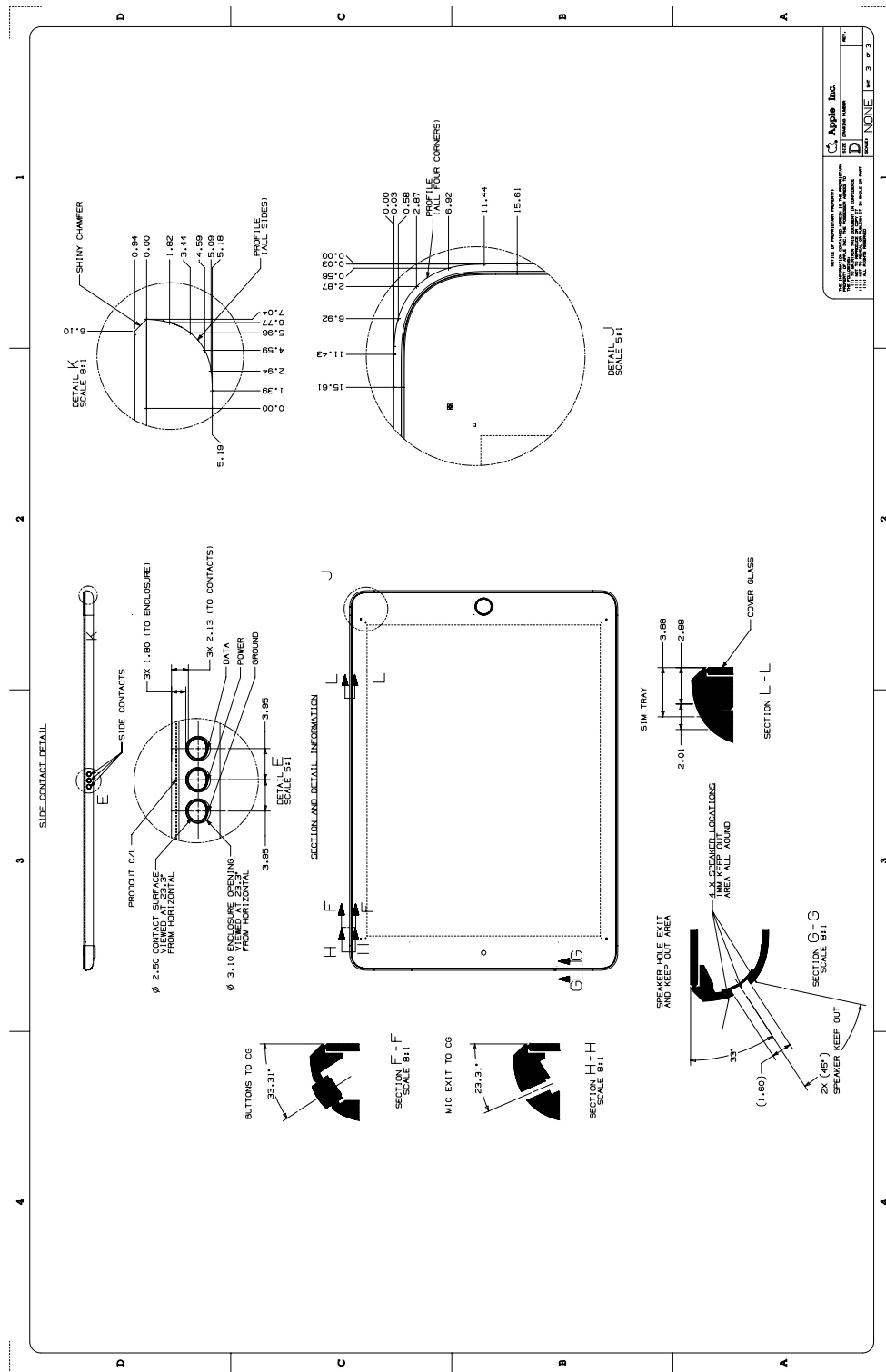

Figure 16-27

iPad Pro (9.7-inch) Magnet/Hall Effect Sensors 2 of 2 Dimensional Drawing



16.24 iPad Pro (12.9-inch) 1st Generation with Wi-Fi

Figure 16-28 iPad Pro (12.9-inch) 1st Generation with Wi-Fi Dimensional Drawing

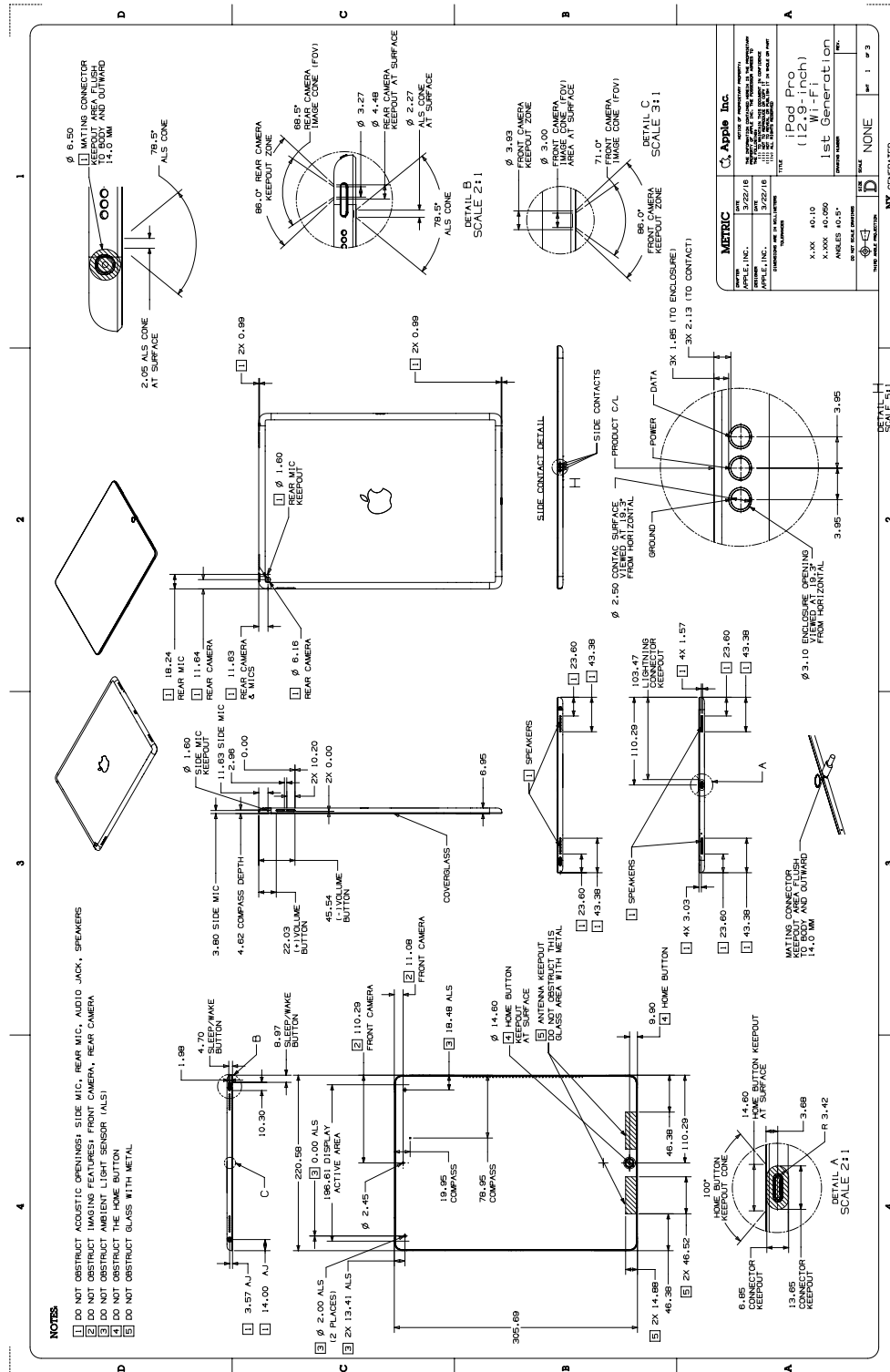

16.28 iPad mini 4 with Wi-Fi + Cellular

Figure 16-33 iPad mini 4 with Wi-Fi + Cellular Dimensional Drawing

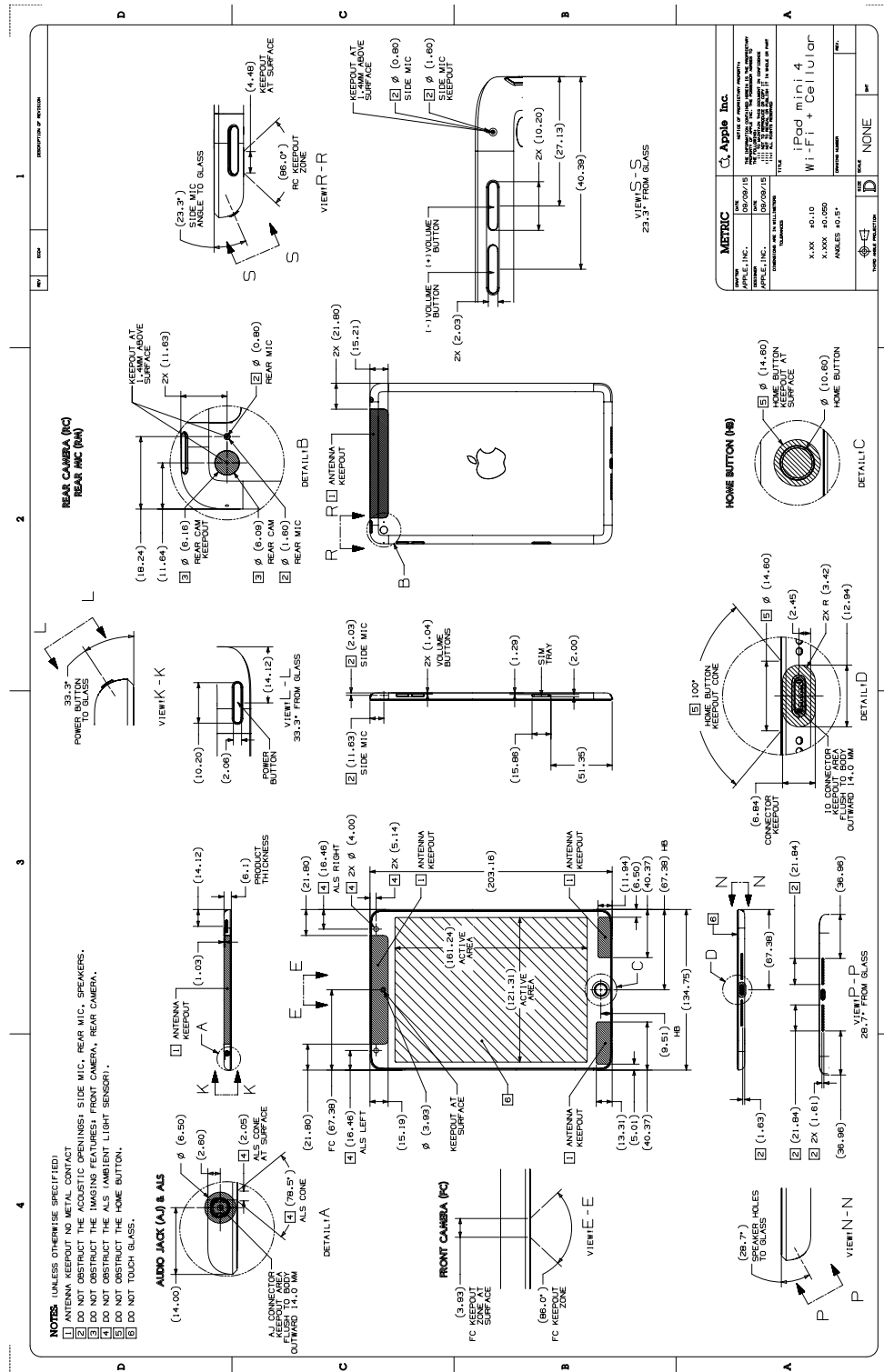

16.29 iPad mini 4 Magnet/Hall Effect Sensors

Figure 16-34 iPad mini 4 Magnet/Hall Effect Sensors Dimensional Drawing

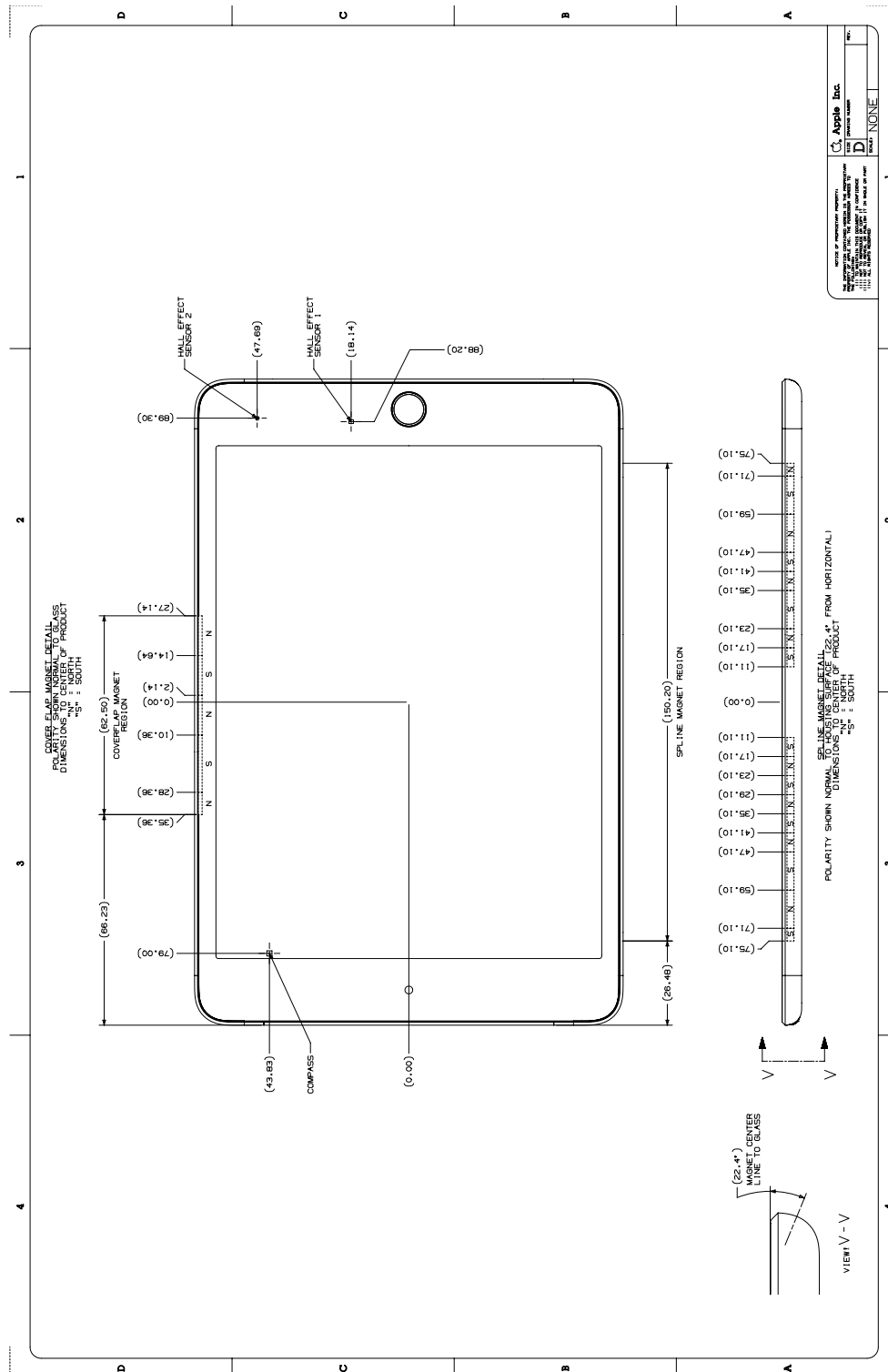

16.30 iPad Air 2 with Wi-Fi

Figure iPad Air 2 with Wi-Fi Dimensional Drawing 16-35

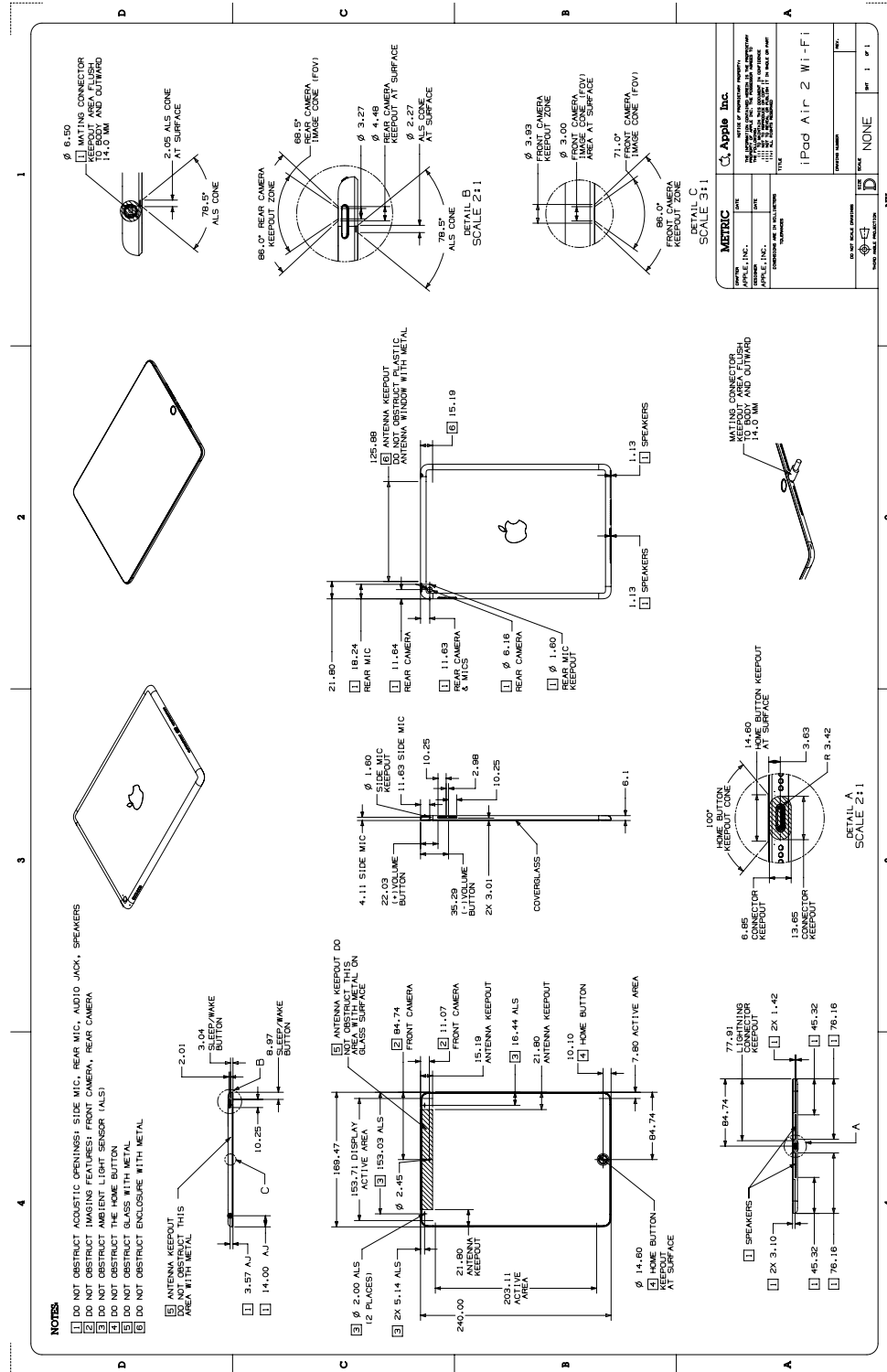

16.31 iPad Air 2 with Wi-Fi + Cellular

Figure iPad Air 2 with Wi-Fi + Cellular Dimensional Drawing
 16-36

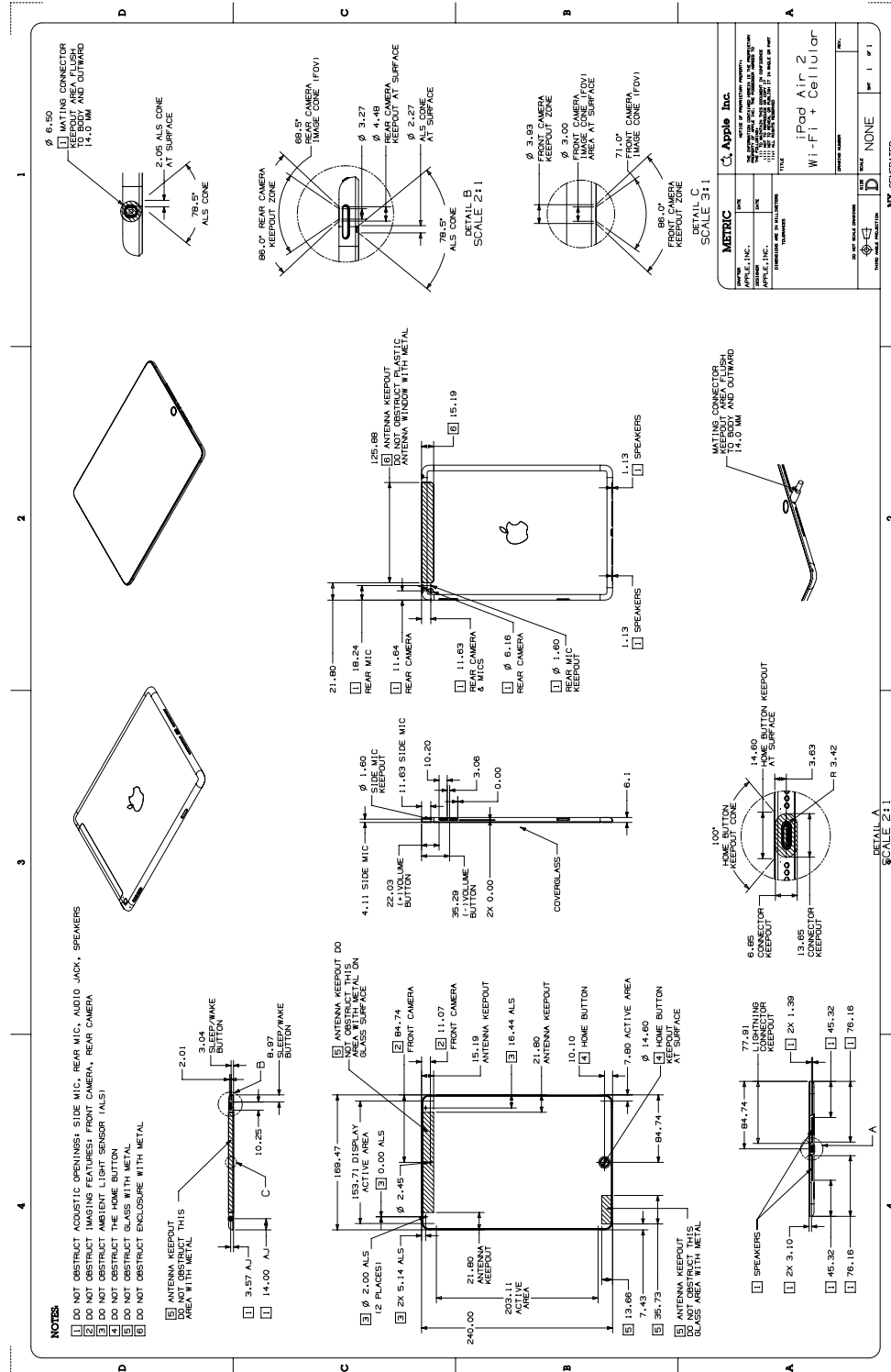

16.38 iPad (4th generation) with Wi-Fi

Figure 16-43 iPad (4th generation) with Wi-Fi Dimensional Drawing

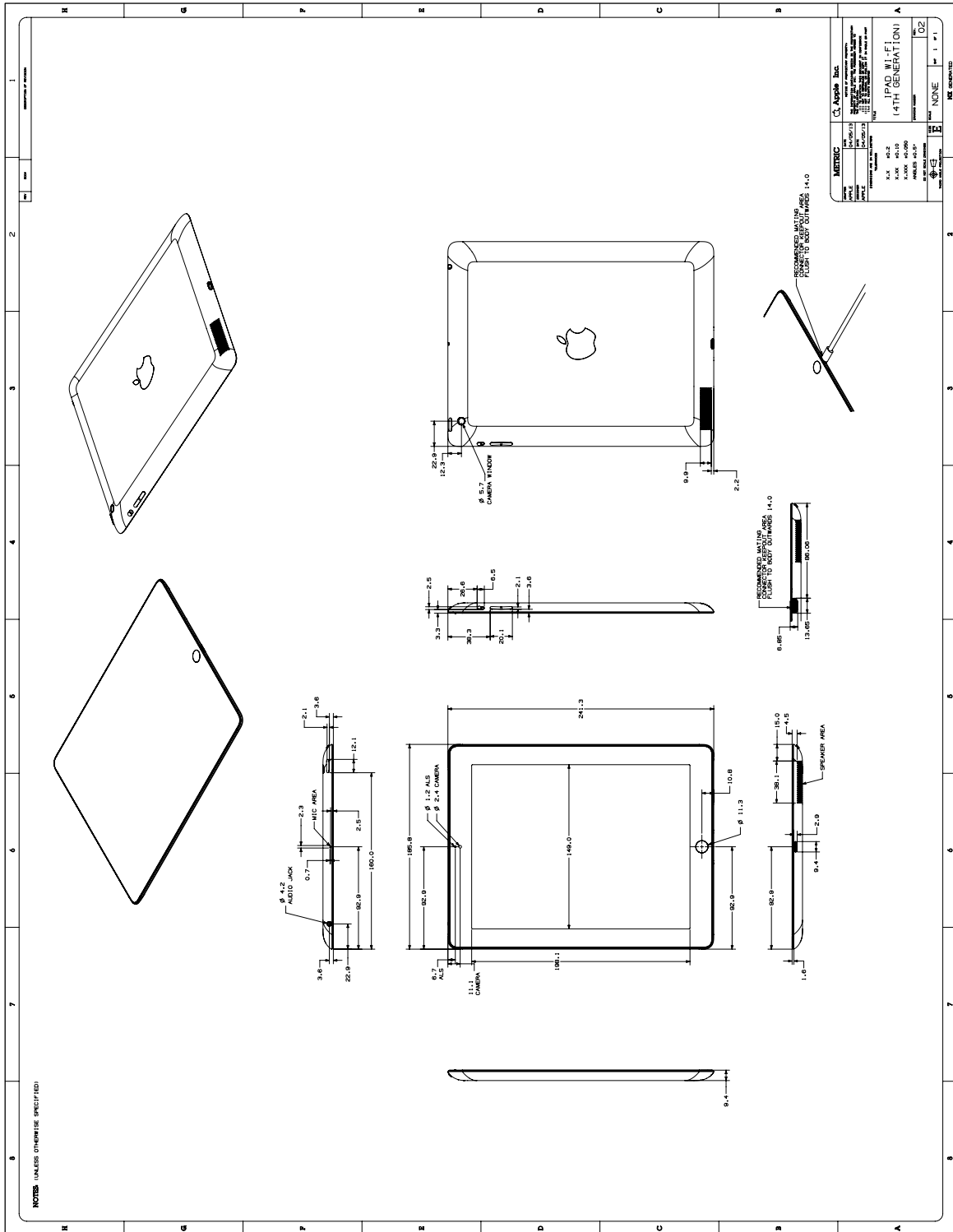

16.39 iPad (4th generation) with Wi-Fi + Cellular

Figure 16-44 iPad (4th generation) with Wi-Fi + Cellular Dimensional Drawing

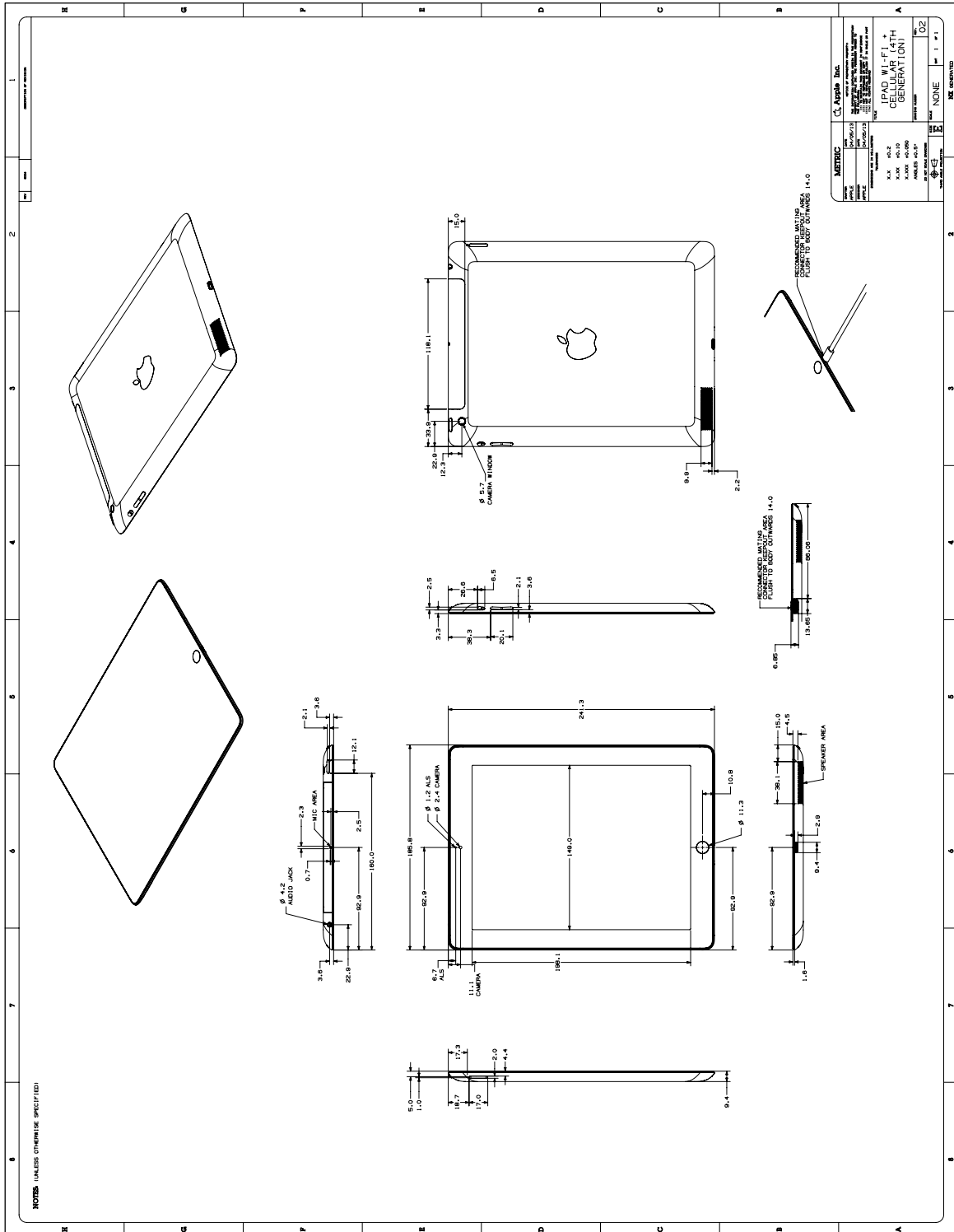

Revision History

This chapter describes changes to the Accessory Design Guidelines for Apple Devices from the previous revision.

Added Content

- [Qi Wireless Power](#) (page 17)
- [HID](#) (page 58)

Updated Content

- [Purpose of This Specification](#) (page 12)
- [Magnetic Interference](#) (page 15)
- [Over The Air \(OTA\)](#) (page 16)
- [Access to Controls](#) (page 19)
- [iPad \(5th and 6th generation\)](#) (page 30)
- [Product Design](#) (page 39)
- [Siri Eyes Free](#) (page 83)
- [Device Dimensional Drawings](#) (page 89)



Apple Inc.
Copyright © 2018 Apple Inc.
All rights reserved

Terms and Conditions ("Terms")

These Guidelines are made available to you for informational purposes only. If you make or distribute any accessory for an Apple device based on or in connection with these Guidelines ("Accessories"), you agree to the following covenants, terms and conditions:

All intellectual property rights in and to the Guidelines, and all technology described therein, are retained by Apple Inc. ("Apple"). You acknowledge and agree that Apple is not granting you, and nothing contained herein shall constitute or be construed or interpreted as a grant, by implication, estoppel or otherwise, of any license, covenant, immunity, release or right under or with respect to any intellectual property rights of Apple, including without limitation any rights to make, use, have made, sell, import, or otherwise relating in any way to any Apple device or technology described in or relating to the Guidelines.

You agree to follow Apple's Guidelines For Using Apple Trademarks and Copyrights as published on Apple's website at www.apple.com/legal/guidelinesfor3rdparties.html ("IP Guidelines") and as may be modified from time to time. You agree not to use the marks "Apple," the Apple Logo, "Mac," "iPhone," "iPod touch," "iPad," "Apple Watch," "WATCH" or any other marks belonging or licensed to Apple in any way except as expressly authorized in writing by Apple in each instance or as permitted in the IP Guidelines. You agree that all goodwill arising out of your authorized use of Apple's marks shall inure to the benefit of and belong to Apple.

You agree to indemnify, hold harmless, and, at Apple's option, defend, Apple against any claims, causes of action, losses, liabilities, damages, fines, settlements, costs, fees, and expenses (including attorney and other professional fees and expenses) arising out of: (i) your use of the Guidelines, including without limitation, any claims that any Accessory, or the combination of any Accessory with any software, technology, intellectual property, device, apparatus or assembly not supplied by Apple, infringes any patent, copyright, trade secret or other intellectual property right; (ii) the manufacture, use, promotion, distribution, sale, offer for sale, import, other distribution or exploitation or performance of any product, case, cover, band, charging stand, or other Accessory or product incorporating any Accessory, including any personal injury or product liability claims; or (iii) any failure to comply with any of the Guidelines. You will not, without Apple's prior written consent, make any admissions of liability, enter into any settlement that imposes any obligation on Apple, or publicize any settlement details relating to Apple. In addition, for any claims related to these Terms where you do not have an indemnification obligation, you shall provide all reasonable assistance to Apple and/or its counsel in connection with the defense, remedy or mitigation of such claims.

Applicable laws or regulations may impose additional restrictions or requirements on Accessories or products that incorporate the Accessories. You represent and warrant that you are in full compliance with all applicable laws, regulations, and policies in the United States and in any other location in which you engage, in whole or in part, in any activity related to the design, manufacture, marketing, sale or offer for sale, use, or other distribution of Accessories or products that incorporate the Accessories. You agree to promptly notify Apple of any complaints or threats of complaints regarding products that incorporate the Accessories with respect to any such regulatory requirements, in which case Apple may limit or terminate your ability to make, sell or purchase additional Accessories.

You expressly acknowledge and agree that access to the Guidelines is at your sole and entire risk and that you are solely responsible and liable for any harm or damage to any Apple product arising out of any breach by you of these covenants, terms and conditions. THE GUIDELINES ARE PROVIDED "AS IS" AND WITHOUT REPRESENTATION, WARRANTY, UPGRADES OR SUPPORT OF ANY KIND. APPLE AND APPLE'S DISTRIBUTORS, AFFILIATES, LICENSOR(S) AND SUPPLIER(S) ("APPLE PARTIES") EXPRESSLY DISCLAIM ALL REPRESENTATIONS, WARRANTIES AND CONDITIONS, EXPRESS OR IMPLIED, INCLUDING THE IMPLIED WARRANTIES AND CONDITIONS OF MERCHANTABILITY, OF SATISFACTORY QUALITY, OF FITNESS FOR A PARTICULAR PURPOSE, OF NON-INFRINGEMENT AND OF ACCURACY. NONE OF THE APPLE PARTIES WARRANTS THAT THE GUIDELINES OR ANY ACCESSORY WILL MEET YOUR REQUIREMENTS, THAT DEFECTS IN THEM WILL BE CORRECTED OR THAT THEY WILL BE COMPATIBLE WITH FUTURE APPLE PRODUCTS. NO ORAL OR WRITTEN INFORMATION OR ADVICE GIVEN BY ANY APPLE PARTY OR AN APPLE AUTHORIZED REPRESENTATIVE WILL CREATE A WARRANTY.

EXCEPT TO THE EXTENT SUCH A LIMITATION IS PROHIBITED BY LAW, IN NO EVENT WILL ANY APPLE PARTY BE LIABLE FOR ANY INCIDENTAL, SPECIAL, INDIRECT, CONSEQUENTIAL, EXEMPLARY OR PUNITIVE DAMAGES, INCLUDING LOST PROFITS, LOST REVENUES OR BUSINESS INTERRUPTIONS, ARISING OUT OF OR RELATING TO THE GUIDELINES UNDER A THEORY OF CONTRACT, WARRANTY, TORT (INCLUDING NEGLIGENCE), PRODUCTS LIABILITY OR OTHERWISE, EVEN IF ANY APPLE PARTY HAS BEEN ADVISED OF THE POSSIBILITY OF SUCH DAMAGES, AND NOTWITHSTANDING THE FAILURE OF ESSENTIAL PURPOSE OF ANY REMEDY. IN NO EVENT WILL THE APPLE PARTIES' TOTAL LIABILITY TO YOU FOR ALL DAMAGES AND CLAIMS UNDER OR RELATED TO THE GUIDELINES EXCEED THE AMOUNT OF US\$50.00.

These Terms will be governed by and construed and enforced under the laws of the United States and the State of Delaware, except that the arbitration clause and any arbitration hereunder shall be governed by the Federal Arbitration Act, Chapters 1 and 2. The United Nations Convention on Contracts for the International Sale of Goods shall not apply to these Terms. All disputes arising out of or in connection with these Terms shall be finally settled under the Rules of Arbitration of the International Chamber of Commerce by one arbitrator appointed in accordance with such rules, and shall be conducted according to the International Bar Association Rules on the Taking of Evidence in International Arbitration. The arbitration shall take place in San Francisco, California. The arbitration shall be conducted in English. The award shall be rendered within six months of the commencement of the arbitration, unless the arbitrator determines that the interest of justice requires that such limit be extended.